



USER GUIDE

Polycom[®] VVX[®] Business Media Phones for BluIP Private Partner Customers

**Applies to Polycom VVX 101, 201, 300, 310, 400, 410,
500, 600, and 1500 phones, Polycom VVX Camera,
and Polycom VVX Expansion Modules**



Trademarks Polycom®, the Polycom logo and the names and marks associated with Polycom products are trademarks and/or service marks of Polycom, Inc. and are registered and/or common law marks in the United States and various other countries.



All other trademarks are property of their respective owners. No portion hereof may be reproduced or transmitted in any form or by any means, for any purpose other than the recipient's personal use, without the express written permission of Polycom.

Disclaimer While Polycom uses reasonable efforts to include accurate and up-to-date information in this document, Polycom makes no warranties or representations as to its accuracy. Polycom assumes no liability or responsibility for any typographical or other errors or omissions in the content of this document.

Limitation of Liability Polycom and/or its respective suppliers make no representations about the suitability of the information contained in this document for any purpose. Information is provided "as is" without warranty of any kind and is subject to change without notice. The entire risk arising out of its use remains with the recipient. In no event shall Polycom and/or its respective suppliers be liable for any direct, consequential, incidental, special, punitive or other damages whatsoever (including without limitation, damages for loss of business profits, business interruption, or loss of business information), even if Polycom has been advised of the possibility of such damages.

End User License Agreement By installing, copying, or otherwise using this product, you acknowledge that you have read, understand and agree to be bound by the terms and conditions of the End User License Agreement for this product. The EULA for this product is available on the Polycom Support page for the product.

Patent Information The accompanying product may be protected by one or more U.S. and foreign patents and/or pending patent applications held by Polycom, Inc.

Open Source Software Used in this Product This product may contain open source software. You may receive the open source software from Polycom up to three (3) years after the distribution date of the applicable product or software at a charge not greater than the cost to Polycom of shipping or distributing the software to you. To receive software information, as well as the open source software code used in this product, contact Polycom by email at OpenSourceVideo@polycom.com.

Polycom Support Visit the [Polycom Support Center](#) for End User License Agreements, software downloads, product documents, product licenses, troubleshooting tips, service requests, and more.

Table of Contents

Contents

Who Should Read this Guide?	12
Typographic Conventions	12
View Your Phone Keys and Hardware.....	13
VVX 101 and VVX 201 Phones Hardware	14
VVX 300 and VVX 310 Phones Hardware	21
VVX 500 and VVX 600 Phones Hardware	25
VVX 1500 Phone Hardware.....	27
Secure Your Phone with the Security Slot	29
Navigating Your Phone Interface	29
Understanding Phone Screens.....	29
Understanding Phone Icons and Status Indicators.....	33
Entering Information in Data Fields	37
Enter Information Using the Dial Pad	38
Enter Information Using the Onscreen Keyboard.....	39
Inputing Chinese Characters with PinYin	40
Log Into and Lock Your Phone	42
Log Into Your Phone	42
Log Out of Your Phone	43
Change Your Password	43
Sign In Using Your BLUP UC-One Credentials	43
Locking Your Phone	44
Lock Your Phone.....	44
Unlock Your Phone	45
Change Your User Password	45
Audio Calls.....	47
Placing and Answering Audio Calls.....	47
Placing Audio Calls.....	48
Redial a Number	52

Answer Audio Calls.....	52
Switch among the Handset, Headset, and Speakerphone.....	55
Mute and Unmute Audio.....	55
End Audio Calls.....	56
Holding and Resuming Calls.....	56
Hold Calls.....	56
Resume Calls.....	56
Transferring Calls.....	57
Choose a Default Transfer Type.....	57
Transfer a Call.....	57
Parking and Retrieving Calls.....	58
Parking and Retrieving Calls with BluIP.....	58
Managing Multiple Calls.....	62
Managing Calls on VVX 1500 Phones.....	62
Managing Calls on VVX 101, 201, 300/310, 400/410, 500, and 600 Phones.....	63
Managing Calls Remotely.....	65
Managing Calls with BluIP UC-One Anywhere.....	65
Managing Calls with BluIP UC-One Remote Office.....	66
Ignoring or Rejecting Incoming Calls.....	67
Ignore or Silence Incoming Calls.....	68
Reject Incoming Calls.....	68
Reject Calls from a Contact.....	68
Rejecting Calls with Do Not Disturb.....	68
Reject Anonymous Calls.....	70
Redirecting Incoming Calls.....	70
Forwarding Incoming Calls to a Contact.....	70
Divert Calls to a Contact.....	71
Initiating and Managing Audio Conference Calls.....	72
Tips for Conference Calls.....	73
Initiate Conference Calls.....	73
Join Calls to Create a Conference Call.....	73
End Conference Calls.....	74
Hold Conference Calls.....	74
Resume Conference Calls.....	74
Split Conference Calls.....	74
Manage Conference Call Participants.....	74
Working with Shared Lines.....	75
Viewing Missed and Received Calls on Shared Lines.....	76
Hold Calls Privately on Shared Lines.....	76
Create a Personal Ring Group with BluIPUC-One Simultaneous Ring.....	76

Add Numbers to Your Simultaneous Ring List	77
Delete Numbers from the Simultaneous Ring List.....	77
Recording Calls on VVX 500, 600, and 1500Phones.....	100
Guidelines when Recording Calls.....	100
Record a Call	100
Pause a Recording	101
Stop Recording	101
Record Conference Calls.....	102
Browse Recorded Calls	102
Play Recorded Calls	102
Rename a Recording.....	103
Delete Recordings	104
Video Calls	105
Tips for Video Calls	105
Using a VVX Camera with VVX 500 and 600Phones	106
Control the Lens Angle	106
Use the Privacy Shutter	106
Status Indicators and Messages for the VVX Camera	107
Changing Video Call Settings.....	108
Set the Call Rate for Video Calls	108
Stop Video for All Calls	108
Change Video Clarity	109
Changing the Video Call and PIP Displays	109
Place a Video Call on VVX 500, 600, and 1500Phones.....	112
Stop Sending Video	112
Display Video Calls in Full Screen.....	113
Swap Video.....	114
Handling Video and Audio Calls	115
Handle Conference Calls with Video	115
Managing Video Calls without a VVX Camera on VVX 500 and 600 Phones.....	116
Managing Audio and Video Calls.....	116
View Video in Full Screen during Calls	117
Handling a Mixture of Video and Audio-Only Calls.....	118
Place Audio-Only Calls.....	118
Manage Call Lists and Directories.....	119
View Recent Calls	119
View Call Details	120
Save a Recent Contact.....	120

Delete a Contact	120
Edit Recent Contact Entries.....	120
Sort Recent Call Entries	120
Managing the Contact Directory	121
Search for Contacts	121
Add a Contact to the Contact Directory	121
View Contact Information.....	123
Update a Contact's Information.....	123
Delete a Contact	123
Managing the Corporate Directory	124
Searching the Corporate Directory	124
Add Contacts to the Contact Directory.....	125
Search the Outlook Directory	125
Save Outlook Contacts to the Contact Directory.....	127
Searching the BluIP Directory	127
Perform a Simple Search.....	127
Perform an Advanced Search.....	127
Add BluIP Contacts to the Contact Directory	133
Manage Buddy Lists, Favorites, and Contact Lists	133
Managing Favorites.....	134
Add Favorites.....	134
View Favorites	135
Reorder Favorites	135
Using Buddy Lists.....	136
Add Contacts to Your Buddy List	136
Monitor Contacts on Your Buddy List.....	137
View Watcher List	137
Block Contacts from Viewing Your Status.....	137
Managing BluIP UC-One Favorites and Contacts	138
View BluIP UC-One Contacts' Presence Information	138
View BluIP UC-One Contacts and Favorites.....	139
View Contacts and Groups	141
Search for BluIP UC-One Contacts.....	141
Update Your Presence Status	148
Update Your Buddy Status.....	148
Automatically Update Your Buddy Status	148
Access, Send, and Broadcast Messages	149

Access Voicemail and Video Messages	149
Remove Message Alert	150
Send Instant Messages.....	150
Read Instant Messages	151
Reply to Instant Messages	151
Delete Instant Messages	151
Broadcasting Messages with Group Paging	151
Sending and Receiving Pages	152
Changing Group Paging Settings	153
Broadcasting Messages with Push to Talk.....	154
Sending and Receiving PTT Broadcasts	155
Reply to PTT Broadcasts	156
End PTT Broadcasts.....	157
Changing PTT Settings.....	157
Use Applications on Your Phone.....	160
Using the Calendar.....	160
Open the Calendar.....	160
Use Meeting Reminders	162
Joining Calendar Meetings	163
Navigating the Browsers.....	163
View the Idle Browser	164
Use the Web Browser	164
Using the Launch Pad on VVX 1500 Phones.....	166
Access the Launch Pad	166
Open Applications.....	166
Navigate the Launch Pad.....	167
Display the Launch Pad's Main Screen	167
Enable My Info Portal.....	167
Customize Your Phone.....	168
Set the Language	168
Set the Time and Date Display.....	168
Disable the Time and Date Display	169
Setting the Backlight Intensity and Timeout.....	169
Change the Backlight Intensity	169
Change the Backlight Timeout.....	170
Select a Background Picture	170
Adding Personal Photos as Your Background.....	171
Reset Your Background	172

Enable Transparent Line Keys.....	173
Enabling Screen Savers.....	173
Enable Screen Savers.....	173
Use Personal Photos as Screen Savers.....	174
Disable Screen Savers.....	175
Use Your Phone as a Digital Picture Frame.....	176
Performing Tasks in the Picture Frame.....	176
Using Power-Saving Mode.....	177
Change Your Office Hours.....	177
Change Timeouts.....	178
Changing Audio Settings.....	178
Change Incoming Call Notifications.....	178
Set a Ringtone for Incoming Calls.....	179
Set a Ringtone for Individual Contacts.....	179
Change the Volume.....	179
Use Accessibility Features on Your Phone.....	180
Features for Hearing-ImpairedUsers.....	180
Features for Vision-Impaired and BlindUsers.....	181
Features for Mobility-ImpairedUsers.....	182
Extend Your Phone’s Capabilities with Accessories.....	183
Using a Headset with Your Phone.....	183
Connecting a Headset.....	183
Use Your Headset for All Calls.....	184
Using Electronic Hookswitch.....	185
Disconnect Your Headset.....	186
Using Bluetooth Headsets with Your VVX 600 Phone.....	186
Using the Polycom Desktop Connector.....	188
Setting Up and Enabling the Polycom DesktopConnector.....	188
Using the Polycom DesktopConnector.....	191
Connecting Polycom VVX Expansion Modules toYour Phone.....	195
View VVX Expansion Module Hardware Features.....	196
Connect VVX Expansion Modules.....	200
Using VVX Expansion Modules.....	200
Maintenance Tasks.....	213
Investigate Phone Warnings.....	213
Remove Warnings.....	213
Restart the Phone.....	214

Update the Phone Configuration	214
Test Phone Hardware	214
Clean the Touchscreen	215
View Software Details	215
Update the Phone Software.....	215
Exit the Software Update Notification	216
Update Software Later	216
Postpone Software Updates	216
Troubleshoot Issues	218
General Phone Issues	218
Speakerphone Issues	218
USB Port Issues	218
Application Issues	220
Troubleshoot Calendar Issues	220
Login Issues	220
Polycom Desktop Connector Issues.....	220
Headset Issues.....	222
Troubleshoot Audio and Echo Issues	222
Bluetooth Headset Issues.....	222
Recording Issues	222
Get Help.....	224
Copyright, Safety, and Regulatory Notices	225
Service Agreements	225
Governing Law	225
Limitations of Liability	225
Polycom Limited Warranty and Limitation Liability.....	225
Exclusions	226
Warranty Exclusive	226
Safety, Compliance, and Disposal Information	226
Part 15 FCC Rules.....	226
Class B Digital Device or Peripheral.....	227
Class A Digital Device or Peripheral - VVX Expansion Modules	227
Modifications	227
Installation Instructions	227
Plug Acts as Disconnect Device	227
Industry Canada (IC)	228
Industry Canada (IC) - VVX Expansion Modules.....	228

CE and VCCI Mark	228
CE Mark R & TTE Directive (EU only)	228
Japan VCCI	229
WARNING Electrical Safety	229
Russian Compliance	230
Ukrainian Compliance	231
New Zealand Telepermit	231
Connection of this Polycom VVX 1500 VoIP Video Telephone to the Telecom Network	232
UAE	232
Australia	232
Operating Ambient Temperatures	232
Hearing Aid Compatibility (HAC)	233
Waste Electrical and Electronic Equipment (WEEE)	233
Restriction of Hazardous Substances Directive (RoHS)	233
Polycom Take Back	233
Applies to VVX 600 Phones Only	233

Before You Begin

This *Polycom VVX Business Media Phones User Guide* uses a number of conventions that help you to understand information and perform tasks.

Who Should Read this Guide?

This user guide contains overview information for the Polycom® VVX® 101, 201, 300, 310, 400, 410, 500, 600, and 1500 phones, the Polycom VVX Camera, and the Polycom VVX Expansion Modules. This guide is intended for beginning users, as well as intermediate and advanced users who want to learn more about their phone features.

Typographic Conventions

A few typographic conventions, listed next, are used in Polycom guides to distinguish types of in-text information.

Typographic Conventions

Convention	Description
Bold	Highlights interface items such as menus, menu selections, window and dialog box names, soft keys, filenames, and directory names when they are involved in a procedure or user action. Also used to highlight text to be entered or typed.
<i>Italics</i>	Used to emphasize text, to show example values or inputs (in this form: <i><example></i>), and to show titles of reference documents available from the Polycom Support Web site and other reference sites.
Blue Text	Used for cross references to other sections within this document and for hyperlinks to external sites and documents.
<code>Courier</code>	Used for code fragments and parameter names.

Get Started

Before you use your phone, take a few moments to familiarize yourself with its features and user interface. This chapter details your phone's components, the screen layout of your phone, and how to navigate your phone's interface.

The terms “the phone” and “your phone” refer to any of the business media phones. Unless specifically noted in this guide, especially with regard to phone graphics, all VVX phones operate in similar ways.



Note: Accessing features and options

As you read this guide, keep in mind that certain phone features are configurable by your system administrator or determined by your phone environment. As a result, some features may not be enabled or may operate differently on your phone. Additionally, the examples and graphics in this guide may not directly reflect what is displayed or is available on your phone screen.

View Your Phone Keys and Hardware

Use the following figures and tables to understand your VVX phone's hardware features. For more information about attaching phone hardware, including how to connect your phone to the network, see the *Quick Start Guide* for your phone available on your phone's support page on [Polycom Voice Support](#).

VVX 101 and VVX 201 Phones Hardware

The following figure displays the hardware features on the VVX 101 and VVX 201 business media phones. The table lists each numbered feature shown in this figure.

VVX 101 and 201 hardware features

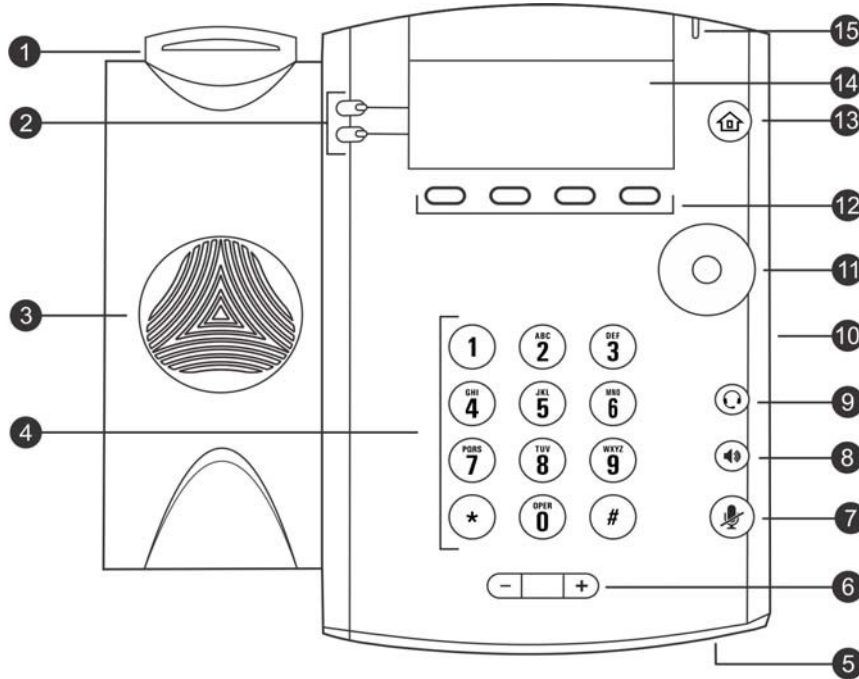

VVX 101 and 201 Hardware Feature Descriptions

<i>Reference Number</i>	<i>Feature</i>	<i>Feature Description</i>
1	Hookswitch	Cradles the handset and end calls.
2	Line keys	Enable you to select a phone line, view calls on a line, or quickly call a favorite contact.
3	Speaker	Provides ringer and speakerphone audio output.
4	Dial pad keys	Enable you to enter numbers, letters, and special characters. You can also use the dial pad keys to select menu items that have index numbers.
5	Microphone	Transmits audio to other phones.
6	Volume keys	Adjust the volume of the handset, headset, speaker, and ringer.
7	Mute key	Mutes local audio during calls and conferences.
8	Speakerphone key	Enables you to place and receive calls using the speakerphone.

VVX 101 and 201 Hardware Feature Descriptions

Reference Number	Feature	Feature Description
9	Headset key	Enables you to place and receive calls through a headset.
10	Security slot (on side)	Enables you to attach a universal security cable lock to your phone so you can secure it to a desktop.
11	Navigation keys / Select key	Scrolls through information or options displayed on the phone's screen. Selects a field of displayed data.
12	Soft keys	Enable you to select context sensitive keys that display along the bottom of the screen.
13	Home key	Displays the Home screen from other screens, and displays the Lines and Calls screen from the Home screen.
14	Screen	Shows a 2.5-inch diagonal screen with a backlight that enables you to view menus and data. VVX 101 phones do not have a backlight.
15	Message Waiting Indicator	Flashes red to indicate when you have new messages.

VVX 300 and VVX 310 Phones Hardware

The following figure displays the hardware features on the VVX 300 and VVX 310 business media phones. The table lists each numbered feature shown in this figure.

VVX 300 and VVX 310 hardware features

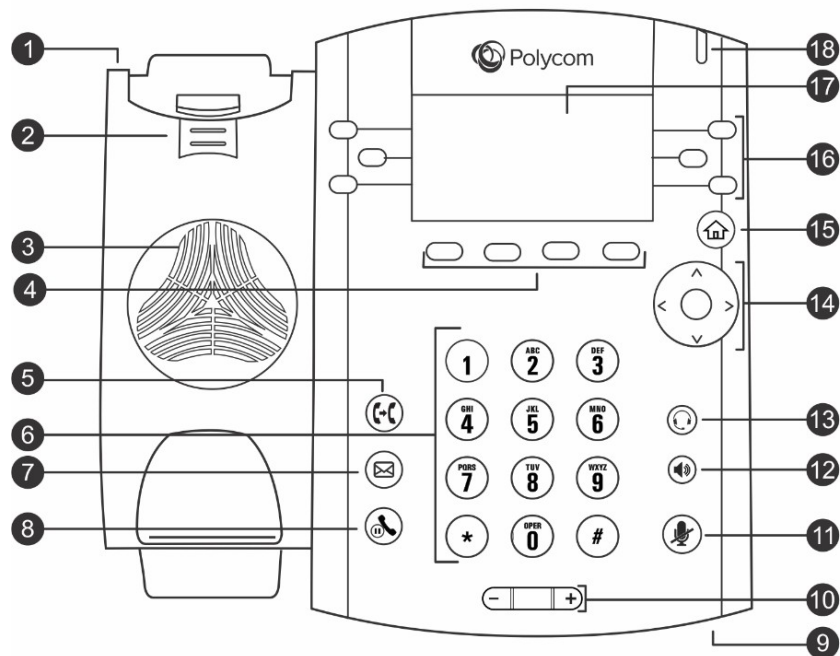

VVX 300 and 310 Hardware Feature Descriptions

Reference Number	Feature	Feature Description
1	Security slot (on top)	Enables you to attach a universal security cable lock to your phone so you can secure it to a desktop.
2	Reversible tab	Secures the handset in the cradle when your phone stand is positioned at a high angle. To secure the handset, remove the tab, reverse it so the protrusion points up, and re-insert it. Position the handset so the protrusion on the tab fits into the slot on the handset.
3	Speaker	Provides ringer and speakerphone audio output.
4	Soft keys	Enable you to select context sensitive keys that display along the bottom of the screen.
5	Transfer key	Transfers an active call to a contact.
6	Dial pad keys	Enable you to enter numbers, letters, and special characters. You can also use the dial pad keys to select menu items that have index numbers.
7	Messages key	Enables you to access and manage instant and voice messages.

VVX 300 and 310 Hardware Feature Descriptions

8	Hold key	Holds an active call or resumes a held call.
9	Microphone	Transmits audio to other phones.
10	Volume keys	Adjust the volume of the handset, headset, speaker, and ringer.
11	Mute key	Mutes local audio during calls and conferences. The key glows red when activated.
12	Speakerphone key	Enables you to place and receive calls using the speakerphone. The key glows green when activated.
13	Headset key	Enables you to place and receive calls through a headset. The key glows green when an analog headset is activated, and blue when a USB or Bluetooth headset is activated.
14	Navigation key/ Select key	Scrolls through information or options displayed on the phone's screen. Selects a field of displayed data.
15	Home key	Displays the Home screen from other screens, and displays the Lines and Calls screen from the Home screen.
16	Line keys	Enable you to select a phone line, view calls on a line, or quickly call a favorite contact.
17	Screen	Shows a 2.2-inch diagonal screen with a backlight that enables you to view menus and data.
18	Message Waiting Indicator	Flashes red to indicate when you have new messages.

VVX 400 and VVX 410 Phones Hardware

The following figure displays the hardware features on the VVX 400 and VVX 410 business media phones. The table lists each numbered feature shown in this figure.

VVX 400 and 410 hardware features

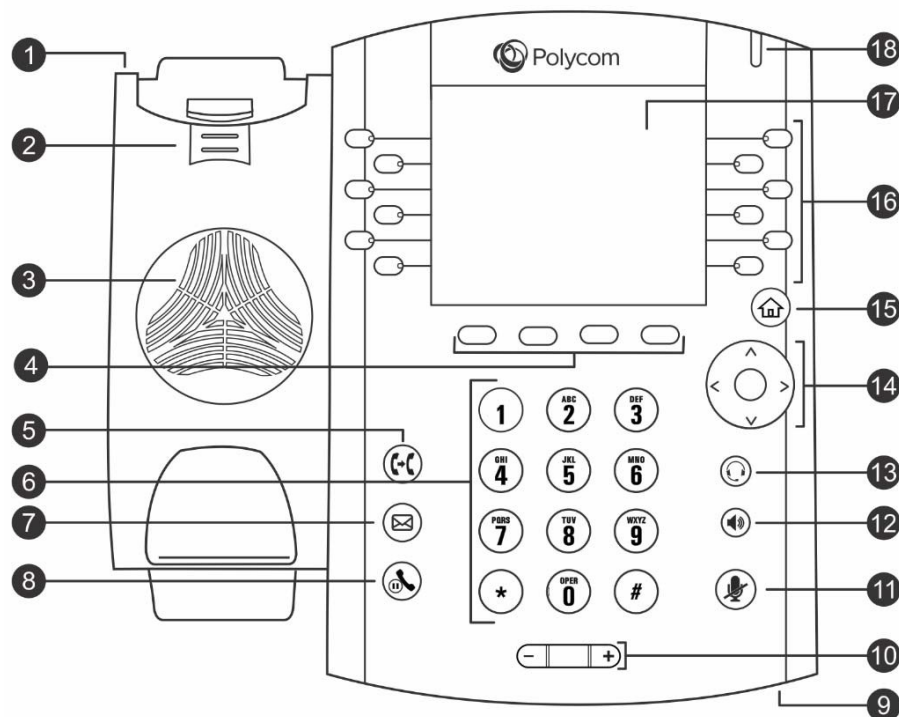

VVX 400 and 410 Hardware Feature Descriptions

Reference Number	Feature	Feature Description
1	Security slot (on top)	Enables you to attach a universal security cable lock to your phone so you can secure it to a desktop.
2	Reversible tab	Secures the handset in the cradle when your phone stand is positioned at a high angle. To secure the handset, remove the tab, reverse it so the protrusion points up, and re-insert it. Position the handset so the protrusion on the tab fits into the slot on the handset.
3	Speaker	Provides ringer and speakerphone audio output.
4	Soft keys	Enable you to select context sensitive keys that display along the bottom of the screen.
5	Transfer key	Transfers an active call to a contact.
6	Dial pad keys	Enable you to enter numbers, letters, and special characters. You can also use the dial pad keys to select menu items that have index numbers.

VVX 400 and 410 Hardware Feature Descriptions

7	Messages key	Enables you to access and manage instant and voice messages.
8	Hold key	Holds an active call or resumes a held call.
9	Microphone	Transmits audio to other phones.
10	Volume keys	Adjust the volume of the handset, headset, speaker, and ringer.
11	Mute key	Mutes local audio during calls and conferences. The key glows red when activated.
12	Speakerphone key	Enables you to place and receive calls using the speakerphone. The key glows green when activated.
13	Headset key	Enables you to place and receive calls through a headset. The key glows green when an analog headset is activated, and blue when a USB or Bluetooth headset is activated.
14	Navigation key/ Select key	Scrolls through information or options displayed on the phone's screen. Selects a field of displayed data.
15	Home key	Displays the Home screen from other screens, and displays the Lines and Calls screens from the Home screen.
16	Line keys	Enable you to select a phone line, view calls on a line, or quickly call a favorite contact.
17	Screen	Shows a 3.5-inch diagonal screen with a backlight that enables you to view menus and data.
18	Message Waiting Indicator	Flashes red to indicate when you have new messages.

VVX 500 and VVX 600 Phones Hardware

The following figure displays the hardware features on the VVX 500 and VVX 600 business media phones. The table lists each numbered feature shown in this figure.

VVX 500 and VVX 600 hardware features

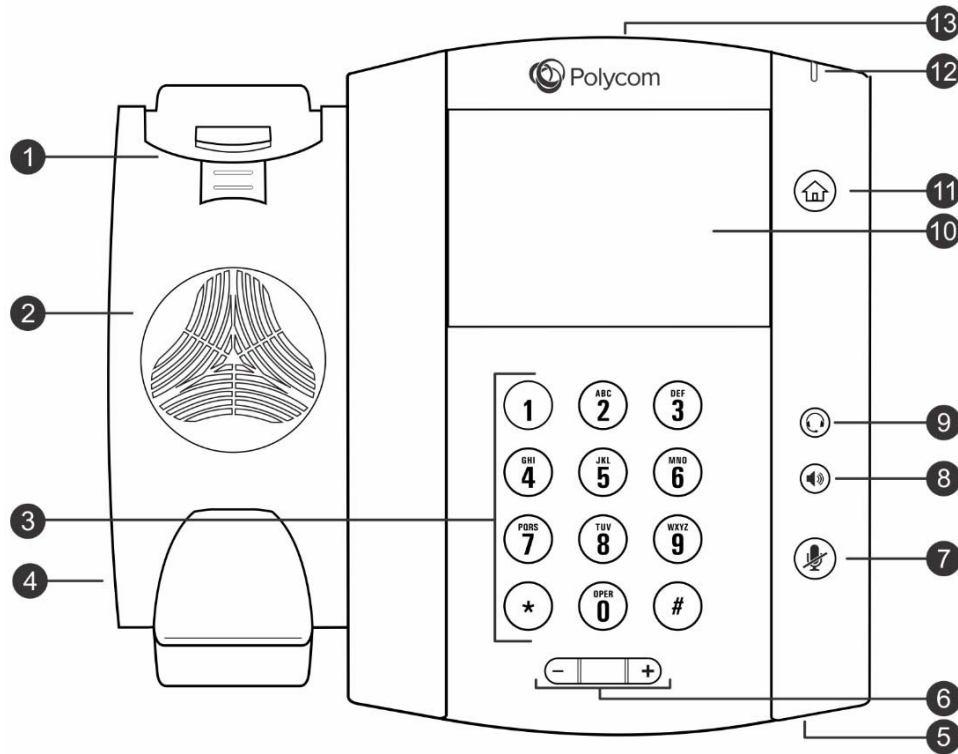

VVX 500 and 600 Hardware Feature Descriptions

Reference Number	Feature	Feature Description
1	Reversible tab	Secures the handset in the cradle when your phone stand is positioned at a high angle. To secure the handset, remove the tab, reverse it so the protrusion points up, and re-insert it. Position the handset so the protrusion on the tab fits into the slot on the handset.
2	Speaker	Provides ringer and speakerphone audio output.
3	Dial pad keys	Enable you to enter numbers, letters, and special characters. You can also use the dial pad keys to select menu items that have index numbers.
4	Security slot (on side)	Enables you to attach a universal security cable lock to your phone so you can secure it to a desktop.
5	Microphone	Transmits audio to other phones.
6	Volume keys	Adjust the volume of the handset, headset, speaker, and ringer.

VVX 500 and 600 Hardware Feature Descriptions

7	Mute key	Mutes local audio during calls and conferences. The key glows red when activated.
8	Speakerphone key	Enables you to place and receive calls using the speakerphone. The key glows green when activated.
9	Headset key	Enables you to place and receive calls through a headset. The key glows green when an analog headset is activated, and blue when a USB or Bluetooth headset is activated.
10	Touchscreen	Enables you to select items and navigate menus on the touch-sensitive screen. Tap the screen to select and highlight screen items. To scroll, touch the screen, and swipe your finger up, down, right, or left.
11	Home key	Displays the Home screen from other screens, and displays the Lines and Calls screens from the Home screen.
12	Message Waiting Indicator	Flashes red to indicate when you have new messages.
13	USB port	Enables you to attach a USB flash drive, a USB headset, or a VVX Camera.

VVX 1500 Phone Hardware

The following figure displays the hardware features on the VVX 1500 business media phone. The table lists each numbered feature shown in this figure.

VVX 1500 hardware features

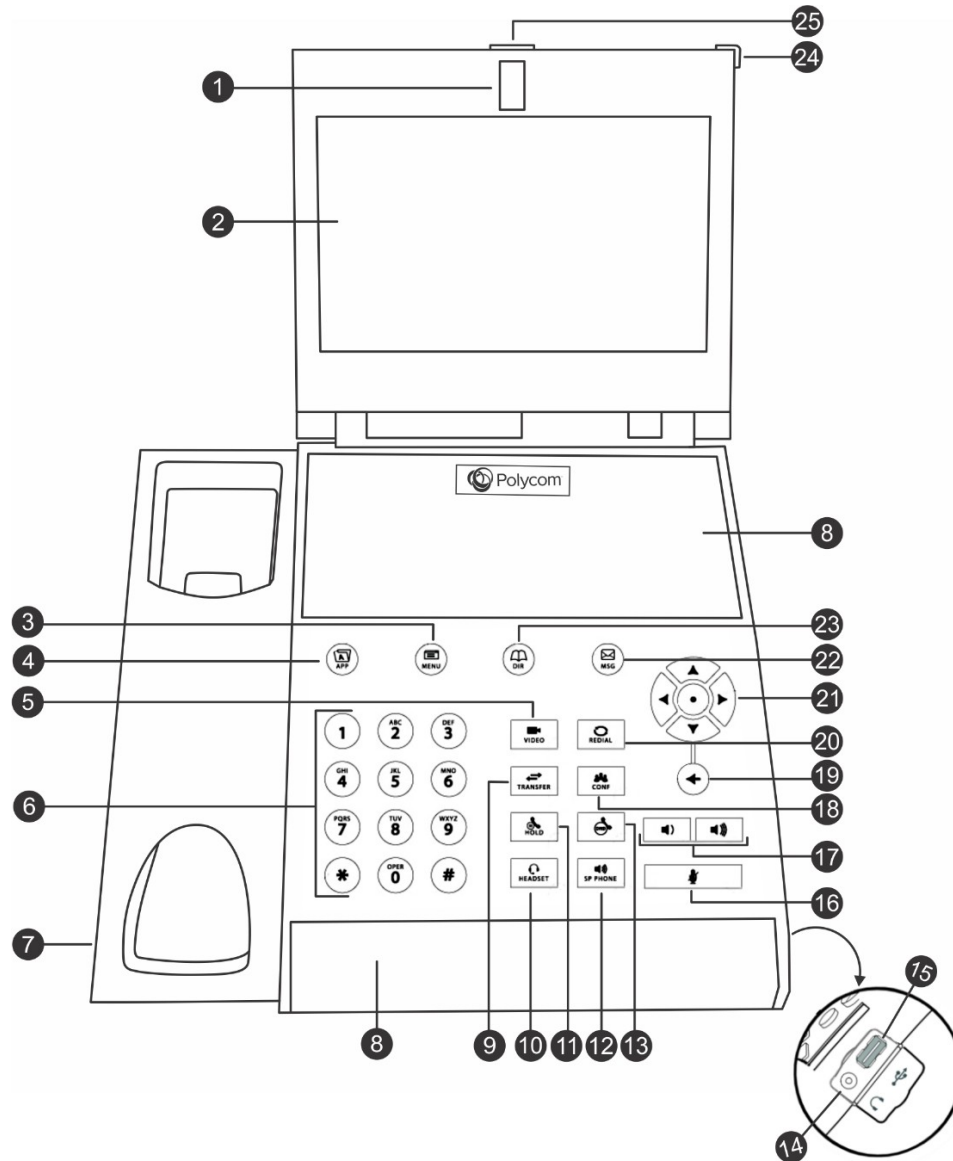

VVX 1500 Hardware Feature Descriptions

Reference Number	Feature	Feature Description
1	Camera	Provides near-site video. The camera barrel is located directly behind the camera lens. The camera barrel adjusts the camera angle.
2	Touchscreen	Enables you to select items and navigate menus on the touch-sensitive screen. Tap the screen to select and highlight screen items on screen. To scroll, touch the screen, and swipe your finger up and down.
3	Menu key	Enables you to access your phone and organization's features as well as other menu options.
4	Applications key	Enables you to access the Web Browser and Launch Pad.
5	Video key	Controls the size, position, and transmission of video images.
6	Dial pad keys	Provide the 10 digits, alphabetic characters, and special characters available in context-sensitive applications.
7	Security slot (on side)	Enables you to attach a universal security cable lock to your phone so you can secure it to a desktop.
8	Speaker	Provides ringer and hands-free (speakerphone) audio output.
9	Transfer key	Transfers a call to another party.
10	Headset key	Enables you to place and receive calls through an optionally connected headset. The key glows green when headset mode is selected.
11	Hold key	Holds an active call or resumes a held call.
12	Speakerphone key	Enables hands-free communication during calls. The key glows green when speakerphone mode is selected.
13	Do Not Disturb key	Cancels ringing and directs incoming calls to your mailbox. The key glows red when activated.
14	Headset connector	Enables you to connect a headset to the phone.
15	USB port	Enables you to connect a USB flash drive to display pictures on your phone, and to record and play back calls.
16	Mute key	Mutes audio transmission locally during calls and conferences. The key glows red when activated.
17	Volume keys	Adjust the volume of the handset, headset, speaker, and ringer.
18	Conference key	Enables connection with another party for a conference.
19	Delete key	Deletes data displayed on the screen.
20	Redial key	Dials your most recently called contact.

VVX 1500 Hardware Feature Descriptions

21	Arrow keys	Enable you to scroll through lists, highlight items, and scroll through active and inactive calls. The Left and Right arrow keys enable you to enable and disable fields, scroll through values for a field, and position the cursor within text to update the text. The Left arrow key also enables you to return to a previous menu.
22	Messages key	Enables you to access and manage instant, voice, and video messages.
23	Directory key	Enables you to access the Contact and Corporate directories, as well as call lists.
24	Message LED Indicator	Flashes red when you have new messages, when the phone is in power-saving mode, and when the software is loading on your phone.
25	Privacy Shutter	Covers and uncovers the camera.

Secure Your Phone with the Security Slot

The security slot is located on the top, left, or right side of the phone and is indicated by a padlock  symbol. See the hardware figure for your phone in the [View Your Phone Keys and Hardware](#) section for the location of the security slot on your phone.

By fastening one end of a universal security cable to a stationary object such as a desk or table, and the other end to the security slot available on Polycom VVX phones, you can prevent your phone from being stolen or otherwise removed. Contact the universal security cable manufacturer directly for more information on securing your phone.

Navigating Your Phone Interface

Your VVX phone has phone icons, status indicators, and phone screens to help you navigate your phone interface and understand important information on the state of your phone. The following topics describe how to navigate your phone's interface:

- [Understanding Phone Screens](#)
- [Understanding Phone Icons and Status Indicators](#)

Understanding Phone Screens

VVX phones have four screens that display on the phones:

- [Home Screen](#) Displays your messages, settings, and information (all VVX phones).
- [Calls Screen](#) Displays all active and held calls on your line (VVX 101, 201, 300, 310, 400, 410, 500, and 600 phones).
- [Lines Screen](#) Displays your phone lines, your favorites, and conditional soft keys (VVX 101, 201, 300, 310, 400, 410, 500, and 600 phones).
- [Active Call Screen](#) Displays the active call currently in progress (VVX 500, 600, and 1500 phones).

Home Screen

On VVX 101, 201, 300, 310, 400, 410, 500, and 600 phones, the phone line and icons you can select to access phone features, settings, and information display on the Home screen. On VVX 1500 phones, your phone line and favorites display on the Home screen. For information on favorites, see the section [Managing Favorites](#).

On VVX 101, 201, 300, 310, 400, 410, 500, and 600 phones, a Page Indicator shows the page you are currently viewing. On VVX 500 and 600 phones, you can press and hold the Page Indicator to control how many icons display on the Home screen. The following figure shows the Page Indicator on the VVX 300 and 310 phones.

Home screen and Page Indicator on VVX 300 and 310 phones



On VVX 500 and 600 phones, you can tap a phone line on the Home screen to display additional phone lines and favorites on your phone, as shown next. From this screen, you can also tap a phone line to open the Dialer or select a favorite to call (see the section [Placing Audio Calls](#)).

Additional lines and favorites from the Home screen on VVX 500 phones



Calls Screen

The Calls screen is supported on VVX 101, 201, 300, 310, 400, 410, 500, and 600 phones. You can access the Calls screen when you have one held call or an active and held call in progress on your phone. The Calls screen is automatically displayed when you have an active call and one or more held calls on your phone.

To display the Calls screen:

- » During a call, do one of the following:
 - Press the Home key .

- On VVX 101 and 201 phones, press the **L→C** soft key.
- On VVX 500 and 600 phones, tap the Calls soft key **< Calls** in the statusbar.
- On VVX 500 and 600 phones, swipe the screen right to left.

All of your active and held calls display on the Calls screen. Use the arrow keys or swipe the screen from the bottom to the top to view all calls on your phone. The total number of calls is displayed on your line, and if you have multiple lines on your phone, calls display under the associated line.

Calls screen on VVX 600 phones

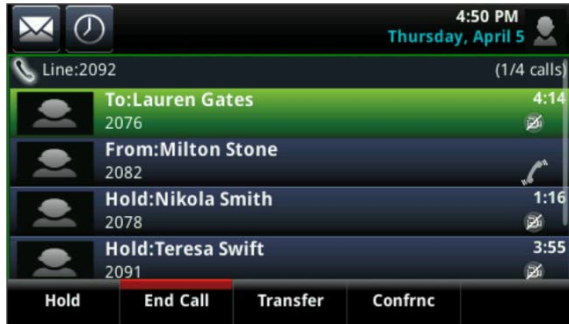

Lines Screen

The Lines screen is supported on VVX 101, 201, 300, 310, 400, 410, 500, and 600 phones and is the default screen when your phone is not in use. You can view your phone lines, favorites, and soft keys on the Lines screen, as shown next.

Phone line, favorites, and soft keys on the Lines screens on VVX 300 and 310 phones

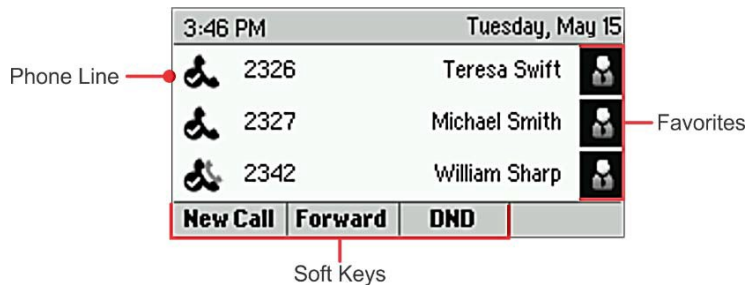

To display the Lines screen:



- » From the **Home** screen, press the Home key .

When you have multiple calls on your phone, the number of calls you have is displayed next to the line number.

Active Call Screen

The Active Call screen is supported on VVX 500, 600, and 1500 phones, and the screen is displayed when you place a call and you have an active call in progress. When you have an active call in progress, the name and number of the contact you are talking with and the duration of the call is displayed in the Active Call screen. In the Active Call screen, you can hold, end, and transfer the call, or set up a conference call.

To display the Active Call screen:

- » Do one of the following:
 - Place a call.
 - On VVX 500 and 600 phones, press the Home key  during an active call.
 - On VVX 500 and 600 phones, tap the Calls soft key  in the statusbar.
 - On VVX 500 and 600 phones, swipe the screen from right to left.

Active Call screen on VVX 500 phones

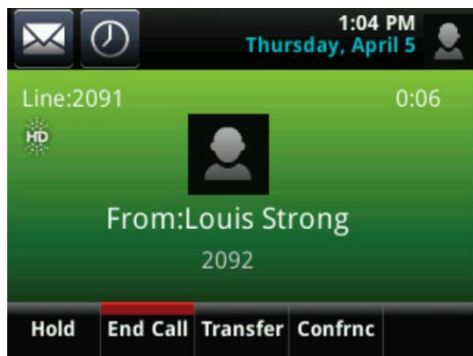

Switch among Phone Screens



You can see any phone screen on your phone from other screens by pressing the Home key , or by swiping your finger from right to left on the touchscreen. Although you can access any phone screen from other screens, you can access certain screens only if your phone is idle or has one or more calls in progress.

You can access certain screens in the following scenarios:

- If your phone is not in use, you can access the Home and Lines screen.
- If your phone has an active call, you can access the all screens.
- If your phone has one active call only, you can access the Home, Lines, and Active Call screens.
- If your phone has multiple calls, or one held call, you can access the Home, Lines, and Calls screen.

On VVX 1500 phones, the Home screen is the default screen, and you can only view the Active Call screen when your phone has an active call in progress. There is no Home key on VVX 1500 phones, and you cannot switch among screens.

To switch among screens:

























- » Do one of the following:
 - From the **Home** screen, press the Home key  to display either the Lines, Calls, or Active Call screen.
The Calls and Active Call screen display only when an active or held call is in progress on your phone.
 - Press the Home key  to display the Home screen from the Lines, Calls, or Active Call screen.
 - On VVX 101 and 201 phones, press the **C→L** soft key to display the Lines screen from the Calls screen.

- On VVX 101 and 201 phones, press the **L→C** soft key to display the Calls screen from the Lines screen.
- On VVX 500 and 600 phones, swipe the screen to the right or left to switch between the Lines, Calls, or Active Call screen.























Understanding Phone Icons and Status Indicators

The following tables display phone icons and status indicators that display on the VVX business media phones. For information on video icons, see the section [Status Indicators and Messages for the VVX Camera](#).







Phone Icons on VVX 101 and 201 Phones

<i>Icon</i>	<i>Description</i>	<i>Icon</i>	<i>Description</i>
	Registered line		Phone warning
	Unregistered line		Login credentials invalid
	Placing a call		Shared line
	Active call using Polycom HD Voice		
	Held call		Call forwarding is enabled
	Incoming call		New message
	Active conference		Presence status (Available)
	Placed call		Presence status (Busy or In a Call)
	Received call		Presence status (Away)
	Missed call		Presence status (Do Not Disturb)
	Favorite		Presence status (Offline)
	Do Not Disturb enabled		Presence status (No information)



















Phone Icons on VVX 300 and 310 Phones

<i>Icon</i>	<i>Description</i>	<i>Icon</i>	<i>Description</i>
	Registered line		Phone warning
	Unregistered line		Login credentials invalid
	Placing a call		Shared line
	Active call using Polycom HD Voice		Call forwarding is enabled
	Held call		New message
	Incoming call		Presence status (Available)
	Active conference		Presence status (Busy or In a Call)
	Placed call		Presence status (Away)
	Received call		Presence status (Do Not Disturb)
	Missed call		Presence status (Offline)
	Favorite		Presence status (No information)
	Do Not Disturb enabled		















Phone Icons on VVX 400 and 410 Phones

<i>Icon</i>	<i>Description</i>	<i>Icon</i>	<i>Description</i>
	Registered line		Phone warning
	Unregistered line		Login credentials invalid
	Placing a call		Shared line

















Phone Icons on VVX 400 and 410 Phones

	Active call using Polycom HD Voice		
	Held call		Call forwarding is enabled
	Incoming call		New message
	Active conference		Presence status (Available)
	Placed call		Presence status (Busy or In a Call)
	Received call		Presence status (Away)
	Missed call		Presence status (Do Not Disturb)
	Favorite		Presence status (Offline)
	Do Not Disturb enabled		Presence status (No information)















Phone Icons and Status Indicators on VVX 500 and 600 Phones

<i>Icon</i>	<i>Description</i>	<i>Icon</i>	<i>Description</i>
	Registered line		Status indicators in Lines screen. A flashing red bar indicates held calls. A green bar indicates an active call.
	Unregistered line		Do Not Disturb enabled
	Placing a call		Phone warning
	Active call using Polycom HD Voice		Login credentials invalid
	Held call		Shared line
	Incoming call in Lines screen		Shared line with a held call
	Incoming call in Calls screen		Call forwarding is enabled

























Phone Icons and Status Indicators on VVX 500 and 600 Phones

<i>Icon</i>	<i>Description</i>	<i>Icon</i>	<i>Description</i>
	Active conference		Select to access recent calls
	USB flash drive attached		New message.
	Recording in progress or paused (VVX 500 only)		
	Recording paused (VVX 600 only)		
	Recording in progress (VVX 600 only)		
	Placed call		Presence status (Do Not Disturb)
	Received call		Presence status (Offline)
	Missed call		Presence status (No information)
	Bluetooth available (VVX 600 only)		

Phone Icons and Status Indicators on VVX 1500

<i>Icon</i>	<i>Description</i>	<i>Icon</i>	<i>Description</i>
	Buddy Status (Online)		
	Buddy Status (Busy, Do Not Disturb)		
	Buddy Status (Be Right Back, Away, Out to Lunch)		
	Buddy Status (Offline)		
	Busy Lamp Field (BLF) indicator (line is busy)		
	Message waiting indicators		Call on hold (private line)
	Missed calls indicator		Call on hold (shared line)

Phone Icons and Status Indicators on VVX 1500

	Audio muted		Call without Polycom HD Voice (private line)
	Speed Dial Key		Call (shared line)
	USB device attached and idle		Conference call
	USB device attached and playing back		Do Not Disturb
	USB device attached and recording		Forward (Always)
	USB device attached and recording pause		Headset attached
	Presence status (Available)		Line (registered, private)
	Presence status (Busy)		Line (registered, shared)
	Presence status (Away)		Line (unregistered)
	Presence status (Do Not Disturb)		Login credentials invalid
	Presence status (Offline)		Video stopped and muted
	Presence status (No information)		Video stopped

Entering Information in Data Fields

You can enter information and edit fields using the dial pad keys on the phone console or using the onscreen keyboard on VVX 500, 600, and 1500 phones.

Before you enter information into fields, you can choose how to enter the information using the following soft keys:

- **Mode** Enables you to enter just numbers or text in title case, lowercase, or uppercase characters.
- **Encoding** Enables you to enter alphanumeric and special characters as well as characters in special languages.

The following table lists the Mode and Encoding options for the dial pad and the onscreen keyboard.

Mode and Encoding Options

<i>Mode Options</i>	<i>Encoding Options</i>
Abc (to capitalize the first letter only, and use lowercase for the remaining letters)	
ABC (to enter uppercase only)	ABC
abc (to enter lowercase only)	abc
123 (to enter numbers only)	123
	ASCII (for regular text)
	Latin (to enter accented characters)
	Katakana (for Japanese characters)
	Unicode (to store characters as double bytes)
	Cyrillic (for Russian characters)

Abc

When the onscreen keyboard is displayed on VVX 500, 600, and 1500 phones, the Encoding and Mode soft keys are not available. For tips on using the onscreen keyboard, see [Enter Information Using the Onscreen Keyboard](#).

Enter Information Using the Dial Pad

You can use the dial pad keys on your phone console to edit or update field information. The following table describes how to enter different types of data on your phone using the dial pad.

Using the Dial pad Keys to Enter Information

<i>Data Type</i>	<i>Action</i>
Enter numbers, or characters in uppercase, lowercase, or title case mode	
Enter only numbers	Select Encoding or Mode , and select 123 .
Enter text in another language	Select Encoding , and select one of the language options.
Enter a character	Press a dial pad key repeatedly to view the character options and stop when the character you want to enter is displayed in the field. Wait one second, and enter the next character.
Enter a number	Select Encoding or Mode , and select 123 , or press a dial pad key repeatedly to enter the number that displays on that key.

Select **Encoding**



Using the Dial pad Keys to Enter Information

Enter a special character	<p>Select Encoding, and select Abc, ABC, or abc. Press the 1, 0, asterisk (*), or pound (#) key one or more times to enter one of the following special characters:</p> <ul style="list-style-type: none"> • 1 key: ! ' ^ \ @ : 1 • * key: . * - & % + ; () • 0 key: / , _ \$ ~ = ? 0 • # key: # > < { } [] “ ” <p>You cannot access special characters when you are in numerical (123) mode.</p>
Enter a space	<p>Select Encoding, and select one of the alphabetic Abc, ABC, or abc. Press the 0 key.</p> <p>You cannot enter a space when you are in numerical (123) mode.</p>
Delete one or more characters	<p>Use the arrow keys to position the cursor to the right of the character, or drag your finger across the characters until the cursor is positioned to the right of the character(s) you want to delete.</p> <p>Press the Delete key, press the Backspace << soft key, or tap the Delete soft key .</p>

Enter Information Using the Onscreen Keyboard

The onscreen keyboard is available on VVX 500, 600, and 1500 phones, and the keyboard enables you to enter field information using your touchscreen. The onscreen keyboard icon  is displayed on screen when data fields are available. When a data entry field requires only numbers, the onscreen keyboard displays only numbers.

To access and use the onscreen keyboard:

- 1 Tap the onscreen keyboard icon .
- 2 Tap the Mode and Encoding icon  and select **Abc**, **ABC**, **abc**, **123**, or one of the special character options.
- 3 Press your finger on each character you want to enter.
- 4 When you finish, tap the Select icon .

The following table describes how to enter information using the onscreen keyboard.

Using the Onscreen Keyboard to Enter Information

Task	Action
Select an Encoding option (title case, uppercase, lowercase, numbers-only, ASCII, Latin, Katakana, Unicode, Cyrillic)	Tap the Mode and Encoding icon  and select the encoding option you want.
Enter text	Tap Abc and select the characters you want.
Enter uppercase characters	Tap ABC and select the characters you want.
Enter lowercase characters	Tap abc and select the characters you want.

Tap the Mode and Encoding icon  and select the encoding option you want.

Using the Onscreen Keyboard to Enter Information

Enter numbers	Tap 123 and select the numbers you want.
Enter special characters	Tap ASCII and select the characters you want.
Exit the onscreen keyboard, enter the information, and update the next field	
Delete one or more characters	Drag your finger across the characters to highlight them in yellow and tap the Delete icon  .
Replace characters	Highlight the characters you want to replace then enter the new characters.

Tap the **Se**

Inputing Chinese Characters with PinYin

PinYin is a commonly used text input method for Chinese characters. The PinYin text input feature on VVX phones uses Nuance XT9® Smart Input to enable you to enter Chinese characters into text fields using the phone's dial pad keys or onscreen keyboard.



Web Info: About the PinYin text input method

For more information on the PinYin text input method, see the [Nuance's XT9 Smart Input](#) web site.

Using the PinYin Input Widget

You can enter Chinese characters in the contact directory, corporate directory, and browser using the PinYin input widget and the dial pad keys or onscreen keyboard. When you select a data field to edit, the PinYin input widget is automatically displayed when Simplified or Traditional Chinese is set as the displayed language on your phone. The following figure shows the PinYin widget on the VVX 1500 phone.

PinYin input widget in the Contact Directory



Enter Chinese Characters with the Dial Pad Keys

You can use the dial pad keys and the PinYin input widget to enter Chinese characters on your phone.

To enter Chinese characters using the PinYin widget and the dial pad keys:



- 1 Enter the PinYin text that corresponds with the letters on the phone's dial pad. For example, press 7464.
The possible PinYin matches display in the text field with the first match highlighted.
- 2 Press the Star key  to toggle between selections.
The recommendation area shows the possible character matches. For example, when *Qing* is selected, the recommendation area shows 庆情请清青平轻晴萍评 . A navigation indicator is displayed if more matches are available.
- 3 Use the left and right arrow keys or swipe the recommendation area on the touch screen to change the selected character.
- 4 Press the **Select** key to select the character from the recommendation area.
- 5 After the character is selected, it is displayed in the input field at the cursor location.
- 6 Repeat preceding steps until entry is complete.

The PinYin input widget disappears if you press the Pound key  or no keys are pressed for 5 seconds.

Enter Chinese Characters with the Onscreen Keyboard

You can use the onscreen keyboard and the PinYin input widget to enter Chinese characters on your phone.

To enter Chinese characters using the PinYin widget and the onscreen keyboard:

- 1 Tap the onscreen keyboard icon .
- 2 Tap the Mode and Encoding icon  to verify that PinYin is the default input mode.
A list of language options display.
- 3 Ensure that **XT9 PinYin** is selected.
- 4 Enter the PinYin text using the onscreen keyboard.
- 5 Tap the **Select** icon  on the onscreen keyboard to select the character from the recommendation area.
- 6 Repeat preceding steps until entry is complete.

Log Into and Lock Your Phone

Polycom VVX phones enable you to lock your phone, log in to your phone with login credentials, and sign in to BLUe IP UC-One. This section includes the following topics:

- [Log Into Your Phone](#)
- [Log Into a Visitor Desk Phone](#)
- [Sign In Using Your BLUe IP UC-One Credentials](#)
- [Locking Your Phone](#)

If your system administrator has set up user credentials for your phone, you can view your personal phone settings from any phone that is part of your organization. You can log in to a phone by entering your user ID and password, and access your contact directory, speed dials, and phone settings. Contact your system administrator for your user credentials.

When you change phone settings while logged in to another phone, the settings are saved and displayed the next time you log in to your phone.



Note: Placing a call from a logged out phone

When a phone is logged out, you can use the phone to place emergency calls and calls to other pre-determined phone numbers. Pre-determined numbers are set up by your system administrator. For information on how to place authorized calls, see [Place Calls from a Locked or Logged Out Phone](#).

Log Into Your Phone

Depending on how your system administrator set up the user login feature, you may need to log in to a phone before you can use the phone. By default, Polycom phones do not require you to log in before you can use them. However, if you do not log in, you see the phone's default profile.

When you log in, you have full access to your personal phone settings and your directory. After you log out, you can no longer view this information.

To log in to a phone:

- 1 Do one of the following:
 - If you see the **User Login** screen, proceed to step 2.
 - If you do not see the **User Login** screen, select **Settings > Features > User Login > Log in**. For VVX 1500 phones, select **Menu > Features > User Login > Log in**.

- 2 From the **User Login** screen, enter your user ID and password, and select **Log in**.

When your login credentials are accepted, the phone updates to display your personal phone profile. When your credentials are not accepted, the message “User login failed” is displayed, and the User Login screen is displayed again. Check with your system administrator to confirm that your login credentials are correct.

Log Out of Your Phone

After you use a phone, make sure you log out to prevent access to your personal settings.

To log out of a phone:

- 1 Select the **Log out** soft key, or select **Settings > Features > User Login > Log out**.
For VVX 1500 phones, select **Menu > Features > User Login > Log out**.

The **Log out** screen is displayed with a confirmation message.

- 2 Select **Yes**.

Your personal profile is no longer accessible, and the phone displays either the User Login screen for the next user or the default phone profile.

Change Your Password

You can change your password from any phone.

To change your user password:

- 1 Log in to a phone on your network.
- 2 Navigate to **Settings > Features > User Login > Change User Login Password**.
For VVX 1500 phones, select **Menu > Features > User Login > Log in Password**.
- 3 From the **Change User Login Password** screen, enter your old and new password information and select **Enter**.

Your password is changed. The next time you log in to a phone, you need to enter your new password.

Sign In Using Your BluIP UC-One Credentials

You can enter your BluIP UC-One credentials on your phone and register your line. Your system administrator provides you with your BluIP UC-One credentials.

This feature is not available for VVX 1500 phones. Check with your system administrator to find out if this feature is available on your phone.

To sign in to your BluIP UC-One credentials:

- 1 Navigate to **Settings > Basic > UC-One Credentials**.
- 2 Enter the **Server Address**.
- 3 For **User**, enter the username for your account.
- 4 For **Password**, enter your password for your account.

Locking Your Phone

Your system administrator provides you with a user password that you can use to unlock the phone and answer calls when your phone is locked.

Consider locking your phone if you want to:

- Prevent unauthorized outgoing calls.
- Allow only authorized people to answer calls.
- Prevent people from viewing or modifying phone information, such as your directory, call lists, or favorites.

When your phone is locked, you can:

- Make outgoing calls to authorized numbers only.
- Enter a password to answer incoming calls.
- Unlock the phone, make an authorized call, or view the browser, if enabled.
- View messages on the status bar informing you that the phone is locked and that only authorized calls are allowed. Any messages that displayed before the phone was locked do not display.

Lock Your Phone

You can choose how you want your phone to handle incoming calls when it is locked. When you set up your phone to receive incoming calls when locked (the default setting), incoming calls ring on your phone, and you can answer calls by entering your user password. See the section [Answer Calls on a Locked Phone](#) for more information.

When you set up your phone to ignore incoming calls, Do Not Disturb applies to all lines on your phone, and your phone does not ring.

To lock your phone:

- 1 Navigate to **Settings > Basic > Lock Phone**.
For VVX 1500 phones, select **Menu > Settings > Basic > Lock Phone**.
- 2 From the **Lock Phone** screen, select **Allow ringing when locked** (the default setting) if you want your phone to ring when you have an incoming call.
When you choose this option, you can answer a call by entering your password.
- 3 Select **Lock**.
Your phone is locked.



Tip: A quick way to lock your phone

You can quickly lock your phone by selecting the Lock soft key. When you do this, you cannot choose how to handle incoming calls. Your phone uses the default setting or the last setting selected.

Unlock Your Phone

You can unlock your phone using your user password.

To unlock your phone:

- 1 Select **Unlock**.
- 2 Enter your user password and select **Enter**.
The phone unlocks.

Change Your User Password

You can change your user password at any time.

To change your user password:

- 1 Navigate to **Settings > Advanced**.
For VVX 1500 phones, navigate to **Menu > Settings > Advanced**.
- 2 Enter your password, and select **Enter**.
- 3 From the **Advanced** screen, select **Change User Password**.
- 4 From the **Change User Password** screen, enter your old and new password information, and select **Enter**.

Audio Calls

VVX phones enable you to place and answer SIP calls, ignore incoming calls from all or individual contacts, place and manage conference calls, manage calls on shared lines, and perform server-dependent tasks.

This section includes the following topics:

- [Placing and Answering Audio Calls](#)
- [Holding and Resuming Calls](#)
- [Parking and Retrieving Calls](#)
- [Managing Multiple Calls](#)
- [Managing Calls Remotely](#)
- [Ignoring or Rejecting Incoming Calls](#)
- [Redirecting Incoming Calls](#)
- [Initiating and Managing Audio Conference Calls](#)
- [Working with Shared Lines](#)
- [Create a Personal Ring Group with BLUeP UC-One Simultaneous Ring](#)
- [Recording Calls on VVX 500, 600, and 1500 Phones](#)

Placing and Answering Audio Calls

VVX 101 and 201 phones can manage a maximum of 8 active, incoming, and held audio calls at a time. VVX 300, 400, 500, 600, and 1500 phones can manage a maximum of 24 active, incoming, and held audio calls at a time. However, you can have only one active call in progress with numerous other incoming calls or calls on hold on all phones. Additionally, your system administrator can set up your phone to have up to six lines with unique extension numbers, or the same extension number as other lines on your network.

This section includes the following topics:

- [Placing Audio Calls](#)
- [Redial a Number](#)
- [Answer Audio Calls](#)
- [Switch among the Handset, Headset, and Speakerphone](#)
- [Mute and Unmute Audio](#)
- [End Audio Calls](#)

Placing Audio Calls

You can place audio calls on your phone, and you have the option to use the handset, the speakerphone, or a headset.



You can place calls in numerous ways. This section includes the following topics on placing calls:

- [Place Calls from the Dialer](#)
- [Place an International Call](#)
- [Place Calls from Recent Call Lists](#)
- [Place Calls to Favorites](#)
- [Place Calls from Directories](#)
- [Place Calls from a Locked or Logged Out Phone](#)
- [Place an Intercom Call](#)
- [Place a Call from a VVX Expansion Module](#)
- [Place a Call with a Hidden Number](#)

Place Calls from the Dialer

The Dialer enables you to enter a number to place a call and displays a list of previously placed calls. As you enter numbers, the Dialer displays a list of similar numbers in your directory. Select a match to automatically enter the number.

To place a call from the Dialer:

- 1 Do one of the following:
 - Start typing a phone number.
 - Press a line key.
 - Pick up the handset, or press the Speakerphone key  or Headset key .
 - Select **New Call**.
- 2 Enter a number or select a recent contact.

On VVX 500, 600, and 1500 phones, tap the onscreen keyboard icon  to use the onscreen dial pad to enter numbers.
- 3 On VVX 101, 201, 300/310, 400/410, and 1500 phones, select **Dial**.

On VVX 500 and 600 phones, tap the Dial icon .



Note: Handling automatically placed calls

Your administrator can set up your phone to automatically place the call after you enter a certain number of digits. If a call is placed before you enter all the digits, add the number to your Contact Directory and dial the number from the Contact Information screen. See the section [Place Calls from Directories](#).

Place an International Call

You can place calls to international phone numbers from the Dialer.

To place an international call:

- 1 In the **Dialer**, quickly press the **star key** * twice.
A plus sign + is displayed.
- 2 Enter the rest of the number and press **Dial** or tap the Dial icon .

Place Calls from Recent Call Lists

In addition to the Dialer, you can place calls from the Recent Calls list, which has calls that were recently placed, answered, or missed on your phone.

To place calls from the Recent Calls list:

- 1 Do one of the following:
 - On VVX 101, 201, 300/310, and 400/410 phones, navigate to **Directories > Recent Calls**.
 - On VVX 500 and 600 phones, tap **Directories > Recent**.
 - On VVX 1500 phones, press the **Directory** key, and select **Call Lists**.
- 2 From the **Calls List** screen, select a contact and select **Dial**. On VVX 500 and 600 phones, the call is automatically placed after you select a contact.

Place Calls to Favorites

You can place a call to your favorites from the Favorites list, from the New Call screen, or by selecting a favorite on your Home or Lines screen. On VVX 1500 phones, you can dial a favorite on the Home screen.

When you add a contact as a favorite, the contact is added to your Favorites list, and you can call contacts directly from the Favorites list.

To place a call from your Favorites list:

- 1 Select **New Call**.
- 2 From the **Dialer**, select **Favorites**.
- 3 Select a favorite, and select **Dial**. On VVX 500 and 600 phones, the call is automatically placed after you select a favorite.

Call a Favorite from the Home or Lines Screen

Contacts you add as favorites display on the Home screen, and you can quickly call favorites from the Home screen.

To place a call to a favorite from the Home or Lines screen:

- » Do one of the following:
 - On VVX 101, 201, 300/310 and 400/410 phones, press a line key associated with a favorite.
 - On VVX 500 and 600 phones, press the Home key , tap your phone line, and tap a favorite.

- On VVX 1500 phones, tap a favorite.
A call is placed to the favorite automatically.

Place Calls from Directories

You can place a call to a contact directly from your directory or you can select contacts in your directory to call from the New Call screen.

To call a contact from your directory:

- 1 Do one of the following:
 - Select **Directories**.
 - Navigate to **New Call > Directory**.
 - On the VVX 1500, press the **Directory** key.
- 2 Choose a directory.
- 3 From your directory, select a contact.
- 4 From the **Contact Information** screen, select the contact's phone number.
The call is automatically placed on VVX 500 and 600 phones.
- 5 On VVX 101 201, 300/310, 400/410, and 1500 phones, select **Dial**.

Place a Call from the Directory Search Screen

You can also call contacts from the Search screen in your directory.

To call contacts from the directory Search screen:

- 1 Select **Directories**.
On VVX 1500 phones, press the **Directory** key.
- 2 Select **Search**, enter your contact's first or last name, and select **Search**.
- 3 Select your contact.
- 4 In the **Contact Information** screen, select the contact's number, and select **Dial**.

Place Calls from a Locked or Logged Out Phone

When your phone is locked or you are not logged into the phone, you can place calls only to emergency numbers, such as 911, and up to five authorized numbers that your administrator can set up. You cannot call any other numbers from a locked or logged out phone.

To call an authorized number from a locked or logged out phone:

- 1 Select **New Call**.
- 2 From the **Place an Authorized Call** screen, select a number, and select **Dial**, or on VVX 500 and 600 phones, tap the Dial icon .

Place an Intercom Call

The intercom on your phone enables you to place a call to a contact that is answered automatically on the contact's phone as long as the contact is not in an active call. If the contact is in an active call, the contact can choose to answer the intercom call, or the intercom call is answered automatically after the active call ends.

Check with your system administrator to find out if this feature is available on your phone.

To place an intercom call:

- 1 From the Home screen, select the **Intercom** icon or select the **Intercom** soft key.
The New Call screen is displayed.
- 2 Enter a number or select a contact.
- 3 Select **Dial**, or on VVX 500 and 600 phones, tap the Dial icon .
The phone plays a tone and the call is answered automatically on the contact's phone.
- 4 Speak your message and wait for a response.
- 5 If you do not need to wait for a response, select **End Call**.



Tip: Quickly call a contact using the intercom

Your system administrator can set up your phone to automatically call a specific contact when you press the Intercom soft key. If your phone is set up this way, press the Intercom soft key and wait for the call to be answered before speaking your message.

Place an Intercom Call during a Call

You can place an intercom call to another contact during an active call.

To use the intercom during a call:

- 1 Select **Hold**, and select the **Intercom** soft key.
The active call is placed on hold and the **New Call** screen is displayed.
- 2 Enter a number or select a contact.
- 3 Select **Dial**, or on VVX 500 and 600 phones, tap the Dial icon .
- 4 After the call is answered, speak your message and select **End Call**.
- 5 Select **Resume**.

Place a Call from a VVX Expansion Module

You can place a call using the line keys on your VVX Expansion Modules. Line keys on expansion modules activate available lines and place calls to contacts assigned to those lines. See the section [Connecting Polycom VVX Expansion Modules to Your Phone](#) for more information on using expansion modules.

To place a call:

- » Do one of the following:
 - Press a line key corresponding to an available line and dial the number.

- Press the line key of the assigned favorite you want to call.
The call is placed and is displayed on your phone's screen.

Place a Call with a Hidden Number

When your phone is registered with BLuIP, you can choose to hide your phone number when you place a call. Check with your system administrator to find out if this feature is available on your phone.

To hide your number:

- 1 Select **UC-One** on the Home screen or navigate to **Settings > Features > UC-One Call Settings**.
On VVX 1500 phones, navigate to **Menu > Settings > Features > UC-One Call Settings**.
- 2 If you have more than one line registered, select a line.
- 3 Select **Line ID Delivery Blocking** and select **Enabled**.
Your number does not display when you place calls to contacts.

Redial a Number

Your phone automatically keeps a record of all the calls placed on your phone. You can recall the last contact you call using the Redial icon or soft key.

To redial a number:

- » Do one of the following:
 - Select the **Redial** icon on the Home screen.
 - Press the **Redial** soft key.

Answer Audio Calls

When you receive an incoming call on your phone, you can choose to answer the call in various ways. This section includes the following topics on answering calls:

- [Answer Calls in the Incoming Call Screen](#)
- [Answer Calls from the Calls Screen](#)
- [Answer a Call When in a Call](#)
- [Answering Calls on Shared Lines](#)
- [Answer Calls Automatically](#)
- [Answer Calls on a Locked Phone](#)
- [Answer Intercom Calls](#)
- [Answer Calls from VVX Expansion Modules](#)

Answer Calls in the Incoming Call Screen

When you receive an incoming call, your phone rings and an Incoming Call screen is displayed, as shown next. In the Incoming Call screen, you can choose to answer or reject the incoming call.



Incoming Call window



Note: Setting up a visual incoming call alert

Your system administrator can enable the screen to flash bright orange when you have an incoming call. The screen continues to flash until the incoming call is displayed in the Home or Calls screen. For more information about this feature, see your system administrator.

To answer an incoming call:

- » Do one of the following:
 - Pick up the handset.
 - Press the Speakerphone key  or select **Answer**.
 - Press the Headset key .
- After you answer the incoming call, the call becomes active.

Answer Calls from the Calls Screen

When you don't answer an incoming call within 10 seconds, the Incoming Call screen disappears, and either the Calls screen is displayed.

To answer the call from the Calls screen:

- » Select the incoming call, and select **Answer**.



Note: Answering calls when your phone is locked

If your phone is locked, you must enter a user password before answering the call. See the section [Answer Calls on a Locked Phone](#).

Answer a Call When in a Call

When you are in an active call and an incoming call arrives on the same or a different line, a call waiting tone beeps, and the Incoming Call screen is displayed.

To answer an incoming call during a call:

- » Select **Answer**.
- The active call is placed on hold, and the incoming call becomes active.

If you don't answer the call within 10 seconds, the Incoming Call screen disappears, and either the Calls screen is displayed.

Answering Calls on Shared Lines

Incoming calls to a shared line causes all registered phones to ring, and the call can be answered on any of the phones. When you or another person answers the incoming call, a green indicator light is displayed on the line key on all phones for the shared line.

You can also choose to ignore the incoming call by selecting **Silence**. The phone stops ringing, and the visual notification continues to display giving you the option to answer the call.

Answer Calls Automatically

You can set up your phone to automatically answer calls using the Auto Answer feature. When this feature is enabled, your phone automatically answers all incoming calls using the speakerphone. Your system administrator sets how many times your phone rings before the call is automatically answered.

When Auto Answer is enabled and you receive an incoming call while in a call, the incoming call is not answered until you end or hold the current call.

To enable your phone to automatically answer calls:

- 1 Navigate to **Settings > Basic > Preferences > Auto Answer**.
For VVX 1500 phones, navigate to **Menu > Settings > Basic > Preferences > Auto Answer**.
- 2 From the **Auto Answer** screen, select **Auto Answer SIP Calls**, and select **Yes**.
- 3 Select **Microphone Mute**, and choose **Yes** (the default setting) to mute the microphone for auto-answered calls.
- 4 For VVX 500, 600, and 1500 phones, select **Video Mute**, and select **Yes** to mute the video when video calls are auto-answered.
The default setting is No. See the section [Video Calls](#) for more information on placing video calls.
- 5 Select **Save**.
These settings are applied to all incoming calls on your phone.

Answer Calls on a Locked Phone

When you set up your phone so that you can answer incoming calls when your phone is locked (see [Locking Your Phone](#)), you can answer calls by entering your user password.

To answer a call on a locked phone:

- 1 From the Incoming Call screen, select **Answer**.
- 2 Enter your user password and select **Enter**.
The call connects.

Answer Intercom Calls

When you receive an intercom call on your phone, the call is answered automatically using the speakerphone. You can switch to the handset or headset after the call is answered (see the section [Switch among the Handset, Headset, and Speakerphone](#)).

If your phone is set up to answer intercom calls with your microphone muted, you need to unmute your microphone before responding to the call.

To answer and respond to an intercom call with mute enabled:

- » After the call is answered, press the **Mute** key and reply.

Answer Calls from VVX Expansion Modules

You can answer calls using the line keys on your VVX phone or from your VVX Expansion Module. See the section [Connecting Polycom VVX Expansion Modules to Your Phone](#) for more information on using expansion modules.

To answer calls:



- » Press the expansion module line key with a flashing green LED indicator.



Switch among the Handset, Headset, and Speakerphone

You can place and answer calls on your phone using the handset, speakerphone, or headset. You can alternate among the three modes during calls, if available.

To switch among the handset, headset, and speakerphone:

- » During a call, pick up the handset, press the Headset key  or press the Speakerphone key .

For example, if you're using the handset, press the Headset key  to switch to the headset, or press the Speakerphone key  to switch to the speakerphone.

When using the speakerphone, the Speakerphone key  glows green. When using the headset, the Headset key  glows green if an analog headset is connected or blue if a USB headset is connected. For VVX 101 and 201 phones, the headset and speakerphone keys do not glow and the Headset  icon displays in the status bar.





Tip: Setting up the phone to automatically use your headset for all calls

If you frequently use a headset, you can set up your phone to always use your headset for calls. For more information, see [Use Your Headset for All Calls](#).

Mute and Unmute Audio

You can mute the microphone so other parties cannot hear you. Microphone Mute applies to the handset, headset, and speakerphone. You can still hear all other parties when you mute your microphone. When your audio is muted, the Mute icon is displayed, and the Mute key glows red, excluding VVX 101 and 201 phones.

To mute and unmute the microphone:

- 1 During a call, including a conference call, press the Mute key  .
The other parties cannot hear you.
- 2 Press the Mute key  again to unmute the microphone.

End Audio Calls

You can end an active call on your phone at any time.

To end active calls:

- » Do one of the following:
 - Place the handset on the cradle.
 - Press **End Call**.
 - In the Calls screen, highlight the call and press **EndCall**.

End Held Calls

You cannot end calls that are on hold. You must resume held calls before ending them.

To end a held call:

- » From the Calls screen, select the held call and press **Resume > End Call**.

Holding and Resuming Calls

When you are in a call, you can place a call on hold and resume the call.

Hold Calls

You can place any active call on hold.

To hold a call:

- » During an active call, select **Hold**. If you're in the Calls screen, highlight the call first.
A hold icon  is displayed on the line of the held call, and a red LED light flashes on the line key for all phones except VVX 101 and 201 phones.

Resume Calls

You can view and resume all held calls in the Active Call, Lines, and Calls screens.

To resume a held call:

- » Do one of the following:
 - Select **Resume**.
 - From the Calls screen, select the call to highlight it, and select **Resume**.

Resume Calls on VVX Expansion Modules

You can resume calls placed on hold by other contacts from your VVX Expansion Module. A flashing red LED light on a line key on the expansion module indicates a call is on hold on the contact's line.

To resume a held call:

- » Press the line key corresponding to the line with the held call.

Transferring Calls

You can transfer active or held calls to another person using the following transfer types:

- *Blind transfer* Transfer calls directly to another line without speaking with the other party first.
- *Consultative transfer* Speak with the other party before completing the transfer.

Choose a Default Transfer Type

You can choose a default transfer type to use for all calls or choose a transfer type during a call. When you choose a default transfer type, you can press the **Transfer** soft key, and your phone uses the set transfer type for all calls. Consultative is set as the transfer type by default.

To set a default transfer type for all calls:

- 1 Navigate to **Settings > Basic > Preferences > Default Transfer Type**.
For VVX 1500 phones, navigate to **Menu > Settings > Basic > Preferences > Default Transfer Type**.
- 2 On the **Default Transfer Type** screen, choose a transfer type.
The selected transfer type is used for all calls.

Transfer a Call

You can transfer a call to another contact and choose the transfer type you want to use for the call.

To transfer a call:

- 1 During a call, do one of the following
 - Press **Transfer** to use the default transfer type.
 - Press and hold **Transfer** and select a transfer type.
- 2 Dial a number or choose a contact from the call list or directory.
If the transfer type is set to Blind, the call is transferred immediately.
- 3 If the transfer type is set to Consultative, press **Transfer** after speaking with your contact.

Cancel a Transfer

If a contact does not answer the transfer or you want to remain speaking with the contact on your line, you can cancel the transfer before it is complete.

To cancel a transfer before the call connects:

- » Select **Cancel**.
The call is not transferred and becomes active.

Parking and Retrieving Calls

Using the Call Park feature, you can park a call on the server or another contact's line and retrieve the call from any phone on your network. The Call Park feature is available on VVX phones registered with BluIP. See the following sections for more information on using Call Park:

- [Parking and Retrieving Calls with BluIP](#)

Parking and Retrieving Calls with BluIP

When your phone is registered with BluIP, you can use Call Park to park a call directly to a contact's line. Call Park is different from call hold in that the call is parked on another contact's line, which enables you to continue using your phone to place other calls. Call Park is also available for shared lines. Check with your system administrator to find out if this feature is available on your phone.

Park Calls

You can park a call directly on a contact's line. When you park a call on a contact's line, the call is removed from your phone, and the contact is notified that a call is parked on his or her line.

To park a call directly to a contact's line:

- » During a call, press **Hold** and dial *68 and the contact's line extension. For example, dial *684144.

When a contact sends a parked call to your extension, the following notifications are displayed or played on your phone:

- The Call Park icon .
- The message "Call is parked" in the status bar
- An audio notification plays, if enabled by your administrator. Audio notifications are not available for BLF monitored contacts.

The Call Park icon  also displays for shared lines, monitored contacts, and for lines and monitored contacts on VVX Color Expansion Modules.

Retrieve Calls

The status message and the Call Park icon **P** continue to display on the phone until the parked call is either retrieved, ignored, or the parked caller ends the call.

If a parked call is not answered after a period of time, which is set by your system administrator, the call is returned to the parker—the person who parked the call. If the parker answers the returned call, the parked call is removed from the parked extension. If the parker rejects the returned call, the parked call remains on the parked extension until the call is returned to the parker and answered, or the parked caller ends the call.

To retrieve a parked call:

- 1 Press and hold the line key with the parked call.
The **Park Info** soft key is displayed.
- 2 Press the **Park Info** soft key.
The **Parked Call** screen is displayed, as shown next.



- 3 Press **Retrieve**.

Retrieve a Parked Call on Another Phone

You can also retrieve a parked call from any phone within your network.

To retrieve a parked call from any phone:

- » Press **New Call** and dial ***88** and the extension the call was parked on. For example, dial ***884144**.

When a parked call is retrieved by a contact monitoring your line, the Call Park icon **P** and status message is removed from the line.

Ignore Parked Calls

You can choose to ignore a parked call instead of retrieving the call. Ignoring the parked call removes the parked call icon, but the call remains parked on your line until the call is retrieved, the retrieval time expires, or the call is ended.

To ignore a parked call:

- 1 Press and hold the line key with the parked call.
The **Park Info** soft key is displayed.

- 2 Press the **Park Info** soft key.
The **Parked Call** screen is displayed.
- 3 Press **Ignore**.
The phone exits the Parked Call screen, and the Call Park icon **P** and status message is removed from the line.

Managing Multiple Calls

You can manage multiple calls that are active, incoming, or held on your phone. The following sections provide information on managing calls on VVX 1500 phones and on the other VVX phones.

Managing Calls on VVX 1500 Phones

When you have active and held calls on VVX 1500 phones, your phone displays the number of calls next to the line key. If you have an active call and numerous held calls on a line, the Active Call screen is displayed and a list of held calls is displayed above the soft keys, as shown next. If you have only held calls on your line, the Active Call screen does not display.

Active and held calls on a VVX 1500 phone



A green bar on the line key indicates the line has an active call, and a flashing red bar indicates the line has one or more held calls.

View a List of Calls

Your phone displays only the list of calls for one line at a time. If you have multiple lines on your phone, you have to select the line to view calls on that particular line.

To view a list of calls on your line:

- » Tap the line.
The line key glows green, and a list of held calls is displayed above the soft keys. The first held call on the line is automatically resumed.

Manage Calls

You can manage a call by holding, resuming, or transferring the call, or you can initiate a conference. When you have more than three held calls on a line, you can press the left and right arrow keys to display the remaining held calls.

To manage calls:

- 1 Tap the line with the held calls.
The first held call on the line is automatically resumed.
- 2 Tap  or use the right arrow key to view additional held calls.
- 3 Tap a held call.
- 4 Do one of the following:
 - Tap **Hold** or press the **Hold** key to place an active call on hold.
 - Tap **Resume** or press the **Hold** key.
 - Tap **End Call** to end a call with a contact. You can end active calls only, so resume the held call first before ending it.
 - Tap **Transfer** to send the call to another contact.
 - Tap **Conference** to initiate a conference call.

Managing Calls on VVX 101, 201, 300/310, 400/410, 500, and 600 Phones

On VVX 101, 201, 300/310, 400/410, 500, and 600 phones, you can see the number of calls for each line from the Lines screen, as shown next. On all VVX phones, a green light on the line key indicates a line with an active call, and a red light indicates a line with one or more held calls.

Multiple Calls on phone lines on the Linescreen

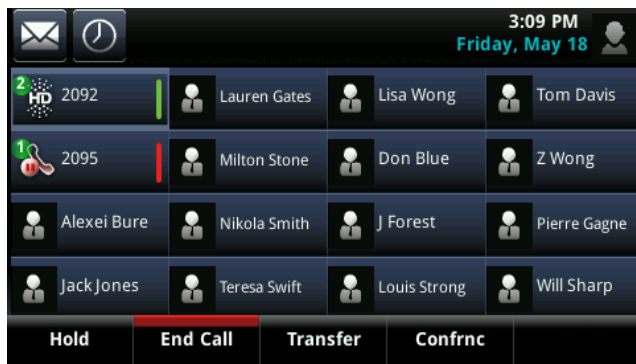

Display Calls from the Lines Screen

You can display the calls for each line from the Lines screen.

To display all the calls for a particular line from the Lines screen:

- » Do one of the following:



- On VVX 101, 201, 300/310 and 400/410 phones, press and hold the line key.
- On VVX 500 and 600 phones, press and hold the phone line.
- On VVX 500 and 600 phones, swipe the screen from right to left.

When you select a phone line that does not have an active call, the first held call on that line is automatically resumed, even if you already have an active call on a different line.

Display Calls from the Calls Screen

You can also view multiple calls on your line from the Calls screen.

To display your calls in the Calls screen:

- » Do one of the following:
 - On VVX 101 and 201 phones, press the **L→C** soft key.
 - From the **Lines** or **Home** screen, press the Home key .
 - On VVX 500 and 600 phones, tap the Calls icon  in the status bar.

The Calls screen is displayed with the list of active and held calls for each line on the phone.

Active and held calls for each line on the Calls screen on VVX 101 and 410

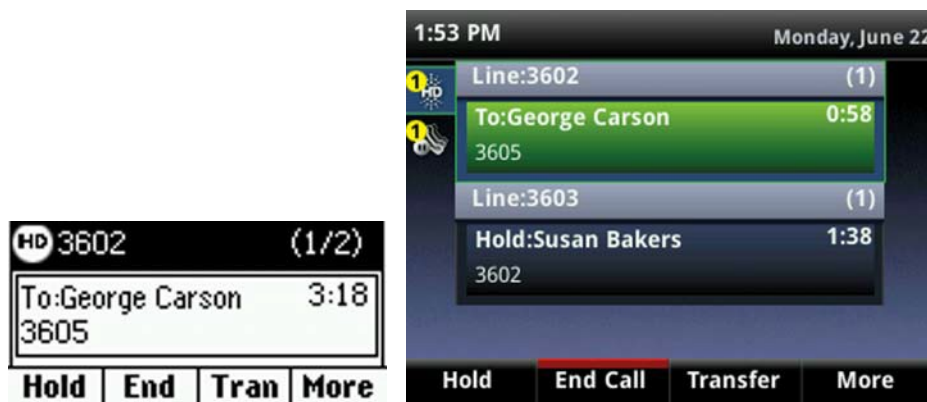

Manage Calls from the Calls Screen

From the Calls screen, you can manage a call by holding, resuming, or transferring the call, or you can initiate a conference.

To manage a call from the Calls screen:

- 1 Select a call.
The call is highlighted.
- 2 Do one of the following:
 - Select **Hold** to place an active call on hold.
 - Select **Resume** to make a held call active.
 - Select **End Call** to end a call with a contact. You can end active calls only, so resume the held call first before ending it.

- Select **Transfer** to send the call to another contact.
- Select **Conference** to initiate a conference call.

Managing Calls Remotely

When your phone is registered with BluIP, and you are signed in to the phone with your BluIP UC-One credentials, you can manage calls to your line remotely from any of your phones using the Anywhere or Remote Office features. With these features, you can handle any incoming calls to your office phone on other phones or mobile devices, and move calls seamlessly from your mobile device to your desk phone without ending the call.

Check with your system administrator to find out if these features are available on your phone.

Managing Calls with BluIP UC-One Anywhere

Anywhere is a BluIP UC-One feature that enables you to use one phone number to receive calls on your desk phone, mobile phone, or home office phone and place calls from any of these phones using one number. Anywhere also enables you to move calls between your desk phone and mobile phone as well as perform any additional functions, such as intercom calls, you would on your desk phone.

Contact your system administrator or your service provider for more information on using Anywhere.

Enable Anywhere

You can enable Anywhere on your VVX phone, add locations that act as duplicates of your desk phone, and manage all your calls from those locations. VVX phones support up to 10 phone numbers added as Anywhere locations for each registered line. You can save a location name, primary number, and alternate number for each location you add.

When you add a location, you can also choose to enable the following settings:

- *Diversion Inhibitor*—Determines if diversion inhibitor must be enabled when extending a call to the remote Anywhere location.
- *Answer Confirmation Required*—Requires confirmation when a call is answered by a remote location.
- *Call Control*—Determines if call control is handled by the Anywhere location or by your BluIP phone.

To enable Anywhere and add locations:

- 1 Select **UC-One** on the Home screen or navigate to **Settings > Features > UC-One Call Settings**.
On VVX 1500 phones, navigate to **Menu > Settings > Features > UC-One Call Settings**.
- 2 Select a line.
- 3 Select **BroadWorks Anywhere** and press **Add**.
- 4 Enter information for the **Status**, **Name**, **Primary Number**, and **Alt. Number/SIP URI** fields, if applicable.
- 5 Choose the settings you want to enable.
- 6 Press **Save**.

Edit Anywhere Locations

After you enable Anywhere and add locations on your VVX phone, you can edit the added locations.

To edit Anywhere locations:

- 1 Select **UC-One** on the Home screen or navigate to **Settings > Features > UC-One Call Settings**.
On VVX 1500 phones, navigate to **Menu > Settings > Features > UC-One Call Settings**.
- 2 Select a line.
- 3 Select **BroadWorks Anywhere** and select a location.
- 4 Edit the selection.
- 5 Press **Save** when you finish editing.

Disable Anywhere Locations

When you return to the office or want to stop remotely managing your calls, you can disable Anywhere locations.

To disable an Anywhere location:

- 1 Select **UC-One** on the Home screen or navigate to **Settings > Features > UC-One Call Settings**.
On VVX 1500 phones, navigate to **Menu > Settings > Features > UC-One Call Settings**.
- 2 Select a line.
- 3 Select **BroadWorks Anywhere** and select a location.
- 4 Select **Status > Disabled**.
- 5 Press **Save**.

Remove Anywhere Locations

You can choose to remove locations that you do not want to manage remote calls from anymore.

To remove an Anywhere location:

- 1 Select **UC-One** on the Home screen or navigate to **Settings > Features > UC-One Call Settings**.
On VVX 1500 phones, navigate to **Menu > Settings > Features > UC-One Call Settings**.
- 2 Select a line.
- 3 Select **BroadWorks Anywhere** and select a location.
- 4 Press **Delete**.

Managing Calls with BLIP UC-One Remote Office

With the Remote Office feature, you can forward all incoming calls to your VVX phone to a remote office number, such as your mobile or home office number, when you are away from the office. You can answer all incoming calls to your desk phone on your mobile phone or home office phone, and any calls you place to contacts from your remote office number shows your desk phone number on the caller ID.

Contact your system administrator or your service provider for more information on using Remote Office.

Add a Remote Office Number

You can add one number only as your remote office number.

To enable Remote Office and add a remote office number:

- 1 Select **UC-One** on the Home screen or navigate to **Settings > Features > UC-One Call Settings**.
On VVX 1500 phones, navigate to **Menu > Settings > Features > UC-One Call Settings**.
- 2 Select a line.
- 3 Select **Remote Office**.
- 4 Enter your remote office number and press **Enabled**.
- 5 Press **Save**.

All calls made to your desk phone are forwarded to the remote office number.

Disable Remote Office

When you return to the office or want to stop forwarding your calls, make sure you disable Remote Office.

To disable Remote Office:

- 1 Select **UC-One** on the Home screen or navigate to **Settings > Features > UC-One Call Settings**.
On VVX 1500 phones, navigate to **Menu > Settings > Features > UC-One Call Settings**.
- 2 Select a line.
- 3 Select **Remote Office > Disabled**.
- 4 Press **Save**.

Edit Your Remote Office Number

You can also edit your remote office number to add a different number for forwarding your calls.

To edit your remote office number:

- 1 Select **UC-One** on the Home screen or navigate to **Settings > Features > UC-One Call Settings**.
On VVX 1500 phones, navigate to **Menu > Settings > Features > UC-One Call Settings**.
- 2 Select a line.
- 3 Select **Remote Office**.
- 4 Enter the new number, and press **Save**.

Ignoring or Rejecting Incoming Calls

When you receive an incoming call, you can choose to ignore or reject the call instead of answering. This section shows you how to reject or ignore incoming calls in the following ways:

- [Ignore or Silence Incoming Calls](#)
- [Reject Incoming Calls](#)
- [Reject Calls from a Contact](#)

- [Rejecting Calls with Do Not Disturb](#)
- [Reject Anonymous Calls](#)



Note: Rejecting calls on shared lines

You cannot reject calls on shared lines. You can only silence the ringer.

Ignore or Silence Incoming Calls

You can ignore or silence a call to stop your phone from ringing. Even if you ignore the call and silence the ringer, an incoming call notification continues to display on your phone.

To ignore or silence a call:

- » From the **Incoming Call** screen, select **Ignore** for private lines, or **Silence** for shared lines.
The **Incoming Call** screen disappears, your phone stops ringing, and either the Home or Calls screen is displayed.

Reject Incoming Calls

You can reject a call and send the call directly to voicemail. Rejected calls display in the Missed Calls list in your Recent Calls list. Rejecting calls is not available for shared lines.

To reject an incoming call:

- » From the **Incoming Call** screen, select **Reject**.
The call goes directly to voicemail.

Reject Calls from a Contact

You can send incoming calls from a particular contact directly to your voicemail.





To reject calls from a contact:

- 1 Navigate to **Directories > Contact Directory**.
On VVX 1500 phones, press the **Directory** key and select **Contact Directory**.
- 2 From your **Contact Directory**, select a contact.
- 3 From the **Contact Information** screen, select **Edit**, or on VVX 500 and 600 phones, tap the Edit icon
- 4 From the **Edit Contact** screen, select **Auto Reject > Enabled** and select **Save**.
Calls from the contact are sent directly to voicemail when the contact calls.

Rejecting Calls with Do Not Disturb

When you enable Do Not Disturb (DND), the following occurs:

- The DND icon is displayed in the status bar on all VVX phones. On VVX 600 phones, you can tap the DND icon in the status bar to enable or disable the feature.

- When your phone is idle, the DND icon is displayed next to your phone line on the Lines screen. If you have new messages or call forwarding is enabled, the messages or forwarding icon is displayed instead.
- The message “Do Not Disturb” is displayed in the status bar on allphones.
- On VVX 400/410, 500, and 600 phones, the DND icon on the Home screen changes from  to . On VVX 300 and 310 phones, the icon changes from  to . For VVX 101 and 201 phones, the line icon changes to .



Troubleshooting: Why doesn't the DND icon display?

When you have set your presence status to Do Not Disturb, as well as enabled DND for your phone, the message My Status: Do Not Disturb scrolls under the time display, and the DND icon does not display in the status bar. See the section [Update Your Presence Status](#) for more information.

Enable Do Not Disturb

You can enable DND to prevent your phone from ringing and to send all incoming calls directly to voicemail. All calls you receive while DND is enabled are logged in your Recent Calls list.

Enabling DND on shared lines disables ringing only. A visual notification of the call still displays, and you have the option to answer or ignore the call.

To enable or disable Do Not Disturb:

- » Select **DND**. On VVX 1500 phones, press the **DND** key.



Tip: Quickly disable DND on VVX600 phones

To disable DND on VVX 600 phones, tap the DND icon , in the status bar.

Reject Calls with Do Not Disturb on Multiple Lines

By default, the Do Not Disturb feature applies to all lines on your phone. your system administrator can set up your phone so that you can enable the feature on a per-line basis.

To automatically enable Do Not Disturb for all lines:

- 1 Select **DND**. On VVX 1500 phones, press the **DND** key.
- 2 Select **Set All** to enable DND for all lines.

Enable DND for One Line

If enabled, you can choose to enable DND for a particular line and not all lines.

To enable Do Not Disturb for a particular line:

- 1 Select **DND**. On VVX 1500 phones, press the **DND** key.
- 2 From the **Line Select** screen, select a line.
- 3 From the **Do Not Disturb** screen, select **Enable**.

Reject Anonymous Calls

When your phone is registered, and you are signed into the phone with your BluIP UC-One credentials, you can use the Anonymous Call Reject (ACR) feature to automatically reject anonymous calls to your line from callers who have restricted their caller identification.

Check with your system administrator to find out if this feature is available on your phone.

To enable Anonymous Call Rejection:

- 1 Select **UC-One** on the Home screen or navigate to **Settings > Features > UC-One Call Settings**.
On VVX 1500 phones, navigate to **Menu > Features > UC-One Call Settings**.
- 2 If your phone has multiple lines, select a phone line.
- 3 Select **Anonymous Call Reject**.
- 4 On the **Anonymous Call Reject** screen, select **Enabled**.

When an anonymous call is placed to your phone number, the call is automatically rejected, and the caller hears a message stating that you do not accept calls from unidentified numbers. Your phone does not ring, and you are not notified of an attempted call.

Redirecting Incoming Calls

You can redirect incoming calls in the following ways:

- [Forwarding Incoming Calls to a Contact](#)
- [Divert Calls to a Contact](#)

Forwarding Incoming Calls to a Contact

You can choose to forward an incoming call to a contact or forward all incoming calls to one of your contacts.

Forward an Incoming Call to a Contact

You can forward an incoming call directly to a contact without answering the call. You cannot forward calls in this way on shared lines.

To forward an incoming call to a contact:

- 1 In the **Incoming Call** screen, select **Forward**.
- 2 From the **Call Forwarding** screen, enter the forwarding number, and select **Forward**.

Forward All Incoming Calls to a Contact

You can set up your phone to forward all incoming calls to a contact using one of the following forwarding types:

- *Always* Forwards all incoming calls.
- *No Answer* Forwards all unanswered incoming calls.
- *Busy* Forwards incoming calls when you're in a call.

For shared lines, you can only choose Always as your forwarding type; the other forwarding options are not available for shared lines.

To forward all incoming calls to a contact:

- 1 Select **Forward** or navigate to **Settings > Features > Forward**.
For VVX 1500 phones, navigate to **Menu > Features > Forward**.
- 2 If your phone has multiple lines, select a line.
- 3 From the **Forwarding Type Select** screen, select a forwarding type.
- 4 Enter a contact's number, URL, or IP address, if enabled, and select **Enable**.
- 5 If you selected the **No Answer** option, enter the number of rings before your phone forwards the call. The default is set to nine.

The forwarding number you chose scrolls in the status bar, and when you select **Always** as your forwarding option, the forwarding icon  is displayed next to the phoneline.

Disable Call Forwarding

You can disable call forwarding when you no longer want to forward your calls.

To disable call forwarding:

- 1 Select **Forward**.
- 2 If your phone has multiple lines, select a line.
- 3 From the **Forwarding Type Select** screen, select your forwarding type, and select **Disable**.

Divert Calls to a Contact

You can divert all incoming calls from a particular contact to another contact.

To divert incoming calls from a contact:

- 1 Select **Directories > Contact Directory**.
On VVX 1500 phones, press the **Directory** key and select **Contact Directory**.
- 2 From the **Contact Directory**, select a contact.
On VVX 1500 phones, select a contact and tap **Edit**.
- 3 From the **Contact Information** screen, select **Edit**, or on VVX 500 and 600 phones, tap the Edit icon .
- 4 From the **Edit Contact** screen, select **Divert Contact**, and enter a contact's number.
- 5 Select **Auto Divert > Enabled**.

6 Select **Save**.

Initiating and Managing Audio Conference Calls

You can initiate an audio conference call with two contacts and hold, resume, or split a conference call on your VVX phone. VVX 101 and 201 phones can manage a maximum of 4 active or held conference calls at a time. All other VVX phones can manage a maximum of 12 active or held conference calls at a time. However, you can have only one active conference call in progress with numerous other conference calls on hold.

If your system administrator enables the Conference Management feature on your phone, you can manage each participant in the call. With the Conference Management feature, you can mute, hold, and remove individual participants in a conference call. For more information, see the section [Manage Conference Call Participants](#).

Tips for Conference Calls

When you are in a conference call, follow these tips:

- Use the handset or a headset if you're in an open environment.
- Mute your microphone when you are not speaking, especially in noisy environments.
- Avoid tapping or rustling papers near the microphone.
- Speak in your normal voice without shouting.

Initiate Conference Calls

You can initiate a conference by calling two people and selecting the **Conference** soft key or hard key.

To initiate a conference call:

- 1 Call a contact.
- 2 After the contact answers, select the **Conference** soft key, or on VVX 1500 phones, press the **Conference** key.
The call is held.
- 3 Enter another contact's number or select a contact from the directory or the call lists.
- 4 When the contact answers, select the **Conference** soft key, or on VVX 1500 phones, press the **Conference** key.

All call participants are added to a conference call.



Note: Single key press conference

When your phone is set up for single key press conferences, you do not need to tap the Conference soft key or press the Conference key a second time to join parties to a conference call.

Join Calls to Create a Conference Call

You can join one active call and one held call into a conference call. If you have more than one call on hold, you can select a held call to join into a conference call with the active call.

To join two calls into a conference call:

- » Do one of the following:
 - When you have an active call and a held call, select the **Join** soft key.
The two calls are joined together in a conference call.

- When you have an active call and more than one held call, select a held call, and select the **Join** soft key.

The active call and the selected held call are joined into a conference while the other held calls on the line remain held.

End Conference Calls

By default, when you end a conference call, your connection to the call ends, and the other participants in the conference remain in the call. However, your system administrator can set up your phone so that all connections terminate when you end a conference call.

To end a conference call:

- » During a conference call, select **End Call**.

Hold Conference Calls

When you place a conference call on hold, you place all conference participants on hold. To place one conference participant on hold, see the section [Manage Conference Call Participants](#).

To place a conference call on hold:

- » Select **Hold**.
- If you're in the Calls screen, highlight the conference first.

Resume Conference Calls

Resuming a held conference call enables all participants to hear the audio of everyone on the call.

To resume a held conference call:

- » Select **Resume**.

Split Conference Calls

When you split a conference, you end the conference call and place the other two people on hold. You can split an active or held conference call. After you split a conference call, you can resume one of the held calls.

To split a conference call:

- » During a conference call, select the **Split** softkey.
- The conference call ends, and the two participants are held in two separate calls.

Manage Conference Call Participants

If your system administrator enables the Conference Management feature on your phone, you can manage conference call participants in the following ways:

- Mute a participant.

- Hold a participant.
- Remove a participant from the conference.
- List information about a participant, such as the participant's name, number, and call details, including whether the call is muted, held, or is video-enabled.

This feature is not available for VVX 101 and 201 phones. Check with your system administrator to find out if this feature is available on your phone.

To manage a participant in a conference call:

- 1 Initiate a conference call.
- 2 Select **Manage**. If you're in the Calls screen, highlight the conference first.
- 3 Select the participant you want to manage.
- 4 Do one of the following:
 - Select **Far Mute** to mute the participant. The muted participant can hear everyone, but no one can hear the muted participant.
 - Select **Hold** to hold the participant. The held participant cannot hear anyone, and no one can hear the held participant.
 - Select **Remove** to remove the participant from the conference, end the conference call, and create an active call between you and the participant still in the call.
 - Select **Information** to view information about the participant's call status. When you select **Information**, a screen is displayed listing the person's information, as shown next.

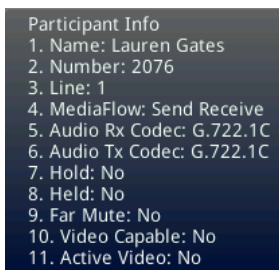

- 5 Select **Back** to exit the conference management function.

Working with Shared Lines

All VVX phones support multiple and shared lines. Your administrator can customize your phone so that you have multiple shared lines enabled.

The following features are not available or have limitations on phones with shared lines:

- Forwarding an incoming call is not available.
- Enabling Do Not Disturb on shared lines disables ringing only, and a visual notification of the call is displayed with the option to answer the call.

This section provides information on the following topics:

- [Viewing Missed and Received Calls on Shared Lines](#)
- [Hold Calls Privately on Shared Lines](#)
- [Barge In on Calls for Busy Lamp Field Lines](#)

Viewing Missed and Received Calls on Shared Lines

When you have an incoming call on a shared line, which none of the phones answer, the call is displayed in the Missed Calls list on all the phones. If you have an incoming call on a shared line and you or any of the other phones answer the call, the call is not logged as missed on anyphone.

Your administrator can configure the phones so that if you have an incoming call on a shared line and one phone answers, the other phones log the call as a received call. That way, if another phone on a shared line answers an incoming call, you can still view the call information from your phone's call lists even if you did not answer the call.

See the section [View Recent Calls](#) for information on viewing missed or received calls.

Hold Calls Privately on Shared Lines

When you place a call on hold on a shared line, all of the phones registered with that line are notified of the call's held status. You can hold a call privately on a shared line using the Private Hold feature, which places the call on hold and displays the line as busy on the other phones on the shared line. Contact your system administrator to find out if this feature is available on your phone.

When the Private Hold feature is enabled, the Pvt Hold soft key is displayed, and you can hold a call privately, transfer a call, or initiate a conference call without notifying others on the shared line of the call's held state.

To hold a call privately on a shared line:

- » During a call, press **More > Pvt Hold**.

The call is held on your phone, and the line shows as busy on the other shared line users' phones.

When you hold a call privately, other users on the shared line cannot resume or pick up the call. However, users on the shared line can barge in on privately held calls. In order to allow other users to resume the call, you have to publicly hold the call by pressing the Hold key or soft key.

When Private Hold is enabled, you can also transfer a call or initiate a conference call without the other shared line users being notified of the call's status. When you press the Transfer or Conference soft key on the shared line, the call is held privately. If you press Hold before you transfer a call or initiate a conference, the other users on the shared line are notified of the call's held status.

See the sections [Transferring Calls](#) and [Initiate Conference Calls](#) for more information.

Create a Personal Ring Group with BLuIP UC-One Simultaneous Ring

When your phone is registered, and you are signed into the phone with your BLuIP UC-One credentials, you can use the Simultaneous Ring feature to add a list of phone numbers that will ring simultaneously when you receive an incoming call on your line. When the incoming call is answered on one of the phones added to your Simultaneous Ring list, the call is logged in the Missed Calls list on the other phones.

Unanswered incoming calls are logged in the Missed Calls lists on all connected phones. Check with your system administrator to find out if this feature is available on your phone.

To enable Simultaneous Ring:

- 1 Select **UC-One** on the Home screen or navigate to **Settings > Features > UC-One Call Settings**.
On VVX 1500 phones, navigate to **Menu > Settings > Features > UC-One Call Settings**.
- 2 Select a line.
- 3 Select **Simultaneous Ring Personal**.
- 4 Select **Status > Enabled**.

Add Numbers to Your Simultaneous Ring List

You can add up to 10 extensions and phone numbers to the Simultaneous Ring list. When you add an extension or a phone number, you can choose to enable Answer Confirmation Required, which notifies you when a call is answered on one of the added numbers.

To add numbers to the Simultaneous Ring list:

- 1 Select **UC-One** on the Home screen or navigate to **Settings > Features > UC-One Call Settings**.
On VVX 1500 phones, navigate to **Menu > Settings > Features > UC-One Call Settings**.
- 2 Select a line.
- 3 Select **Simultaneous Ring Personal > Add**.
- 4 Enter an extension or phone number.
- 5 Select **Answer Confirmation Required** to receive confirmation that the call was answered.
- 6 Press **Save**.

You cannot pick up or barge in on calls answered on another phone. The contact who answers the call must transfer the call to your phone or park the call on your line for you to speak with the caller.

Delete Numbers from the Simultaneous Ring List

You can delete a number added to your Simultaneous Ring list at anytime.

To delete numbers from the Simultaneous Ring list:

- 1 Select **UC-One** on the Home screen or navigate to **Settings > Features > UC-One Call Settings**.
On VVX 1500 phones, navigate to **Menu > Settings > Features > UC-One Call Settings**.
- 2 Select a line.
- 3 Select **Simultaneous Ring Personal**.
- 4 Select the numbers you want to remove and press **Delete**.



Recording Calls on VVX 500, 600, and 1500 Phones

On VVX 500, 600, and 1500 phones, you can record audio calls onto a USB flash drive connected your phone. Recordings are stored as .wav files on the USB flash drive, and you can record up to four hours in one file. For a list of supported USB flash drives to record phone audio, see [Technical Bulletin 38084: Supported USB Devices](#).



Web Info: How do I attach a USB flash drive to my phone?

To attach a USB flash drive, see the Quick Start Guide for your VVX phone on your phone's support page on [Polycom Voice Support](#).

When you attach a USB flash drive to your phone, a USB icon  is displayed in the status bar with a message that tells you how much recording time is available. On the VVX 600, you can tap the USB icon  to view your recordings and USB properties.



Troubleshooting: Why is my USB flash drive not displaying on my phone?

If your phone does not detect the USB flash drive when you attach it to your phone, the USB port on your phone may be disabled. Contact your system administrator and view the section [USB Port Issues](#) for more information.

Guidelines when Recording Calls

The following are a list of guidelines to follow when recording audio calls:

- Inform contacts when you are recording a call.
- Make sure you mute your audio when you are placed on hold while recording the call. When you place a call on hold while recording, the recording pauses. However, when another person places you on hold, the recording continues.
- During an active call, pause your recording before answering incoming calls. All incoming calls you answer after you start recording are also recorded in the same file. For example, on June 22, 2012, at 11:22 a.m., you answer a call from person A. During your call with person A, you answer calls from person B and person C. All three calls are recorded in the same file.

Record a Call

You can record all active calls on your phone. You cannot record calls when there are no connected calls on your phone, when you place a new call to transfer a call or initiate a conference, or when you have an incoming call.

Make sure to inform your contacts on the call before you begin recording.

To record a call:

- » During an active call, select **Record > Start**.

An R is displayed on the USB icon and the message “Recording in progress” is displayed in the status bar.

Note that some tones made on your contact’s phone are recorded. When you press  while recording, your audio is muted and only other participants’ audio in the call are recorded.



Note: Managing a call while you're recording

You can hold, end, transfer, or set up a conference call while you record, or while a recording is paused. To manage a call during a recording, select **Back** and choose the task you want to perform. To see the Recording soft keys again, select **Record**.

Pause a Recording

You can pause a recording during a call at any time while the call is active.

To pause a recording:

- » Select **Pause**.

A P is displayed on the USB icon and the message “Recording Paused” is displayed in the status bar.

Resume a Recording

When you resume a recording after pausing, the recording continues within the same file.

To resume the recording:

- » Select **Resume**.

Stop Recording

You can choose to stop recording a call before the call ends. The recording also stops when the active call ends, no matter who ended the call.

To stop recording:

- » Do one of the following:
 - Select **Stop**.
 - Select **Back > End Call**.

When you stop recording, the USB icon is displayed in the status bar.



Caution: Removing a USB flash drive during a recording

Polycom recommends that you do not remove the USB flash drive while recording. The file being recorded will be incomplete and cannot be played back later. When you remove the USB flash drive while recording, you can also damage the flash drive.

Record Conference Calls

You can record a conference call in the same way as an active call with the following exceptions:

- All conference call participants are recorded. When a conference participant mutes his or her audio, that participant is not recorded.
- When you place a conference call on hold, the recording pauses. You can place or answer other calls, which are recorded in the same file. When you resume the conference call, the recording resumes.

To record a conference call:

- » During an active conference call, select **Record > Start**.

An R is displayed on the USB icon and the message “Recording in progress” is displayed in the status bar.

Browse Recorded Calls

On your phone, you can browse the recorded files stored on the USB drive.

To browse recorded files:

- » Navigate to **Settings > Features > Removable Storage Media > Browse Recordings**.

For VVX 1500 phones, navigate to **Menu > Features > Removable Storage Media > Browse Recordings**.

A list of recordings is displayed, as shown next.



Play Recorded Calls

You can play back calls that you recorded on your USB drive on your phone. You can also play recorded files on a Windows or Apple computer using an application capable of playing .wav files.

To play a recorded call:

- 1 Navigate to **Settings > Features > Removable Storage Media > Browse Recordings**.
For VVX 1500 phones, navigate to **Menu > Features > Removable Storage Media > Browse Recordings**.
- 2 From the **Browse Recordings** screen, select a file, and select **Open**.
- 3 Select **Play**.

The length of the recording and a progress bar is displayed as the recording plays, as shown next.



If the handset is off-hook when you play a recording, the audio plays through the handset. If the handset is on-hook when you play a recording, the audio plays through the speaker.



Note: You cannot play recordings during active calls

You cannot open and play recordings when you are in an active call or if you're recording a call. If you try to, a message indicating that the action was canceled is displayed. Place the call on hold before playing the recordings. The recording stops playing when you resume the call.

Pause and Resume Played Recordings

While you're playing a recording, you can pause the recording, perform another tasks on your phone, and resume the recording at any time.

To pause and resume a recording:

- 1 While the recording plays, select **Pause**.
- 2 Select **Resume** to continue playing the recording.

When you receive an incoming call while playing a recording, the recording is paused automatically. If you do not answer or reject the incoming call, the recording remains paused until you select **Resume**.

Stop Playing a Recording

When you are finished listening to a recording, you can stop playing it by exiting the recording.

To stop playing a recording:

- » Select **Exit**.

Rename a Recording

By default, recordings are labeled with the date of the recording. You can rename recordings to provide them with more meaningful names.

To rename a recording:

- 1 Navigate to **Settings > Features > Removable Storage Media > Browse Recordings**.
For VVX 1500 phones, navigate to **Menu > Features > Removable Storage Media > Browse Recordings**.
- 2 From the **Browse Recordings** screen, select a recording.

- 3 Select **Rename**, update the filename, and select **OK**.

Delete Recordings

When you have played a recording or need additional space on your USB drive, you can delete recordings on your phone.

To delete a recording:

- 1 Navigate to **Settings > Features > Removable Storage Media > Browse Recordings**.
For VVX 1500 phones, navigate to **Menu > Features > Removable Storage Media > Browse Recordings**.
- 2 From the **Browse Recordings** screen, select a recording.
- 3 Select **Delete**.

Video Calls

Your administrator can enable your VVX 500, 600, and 1500 phone to receive and transmit video during calls. The VVX 1500 phones have a built-in camera, but the VVX 500 and 600 phones need a VVX Camera to transmit video. The VVX Camera is an optional accessory that attaches to the USB port on the VVX 500 and 600 phones. See the [VVX Camera Support](#) page for information on how to attach the camera to your phone.

If you do not have a VVX Camera attached to your VVX 500 or 600 phone when you receive video during calls, you can see your contact's video, but your contact cannot see video from you.

The following topics are included in this section:

- [Tips for Video Calls](#)
- [Using a VVX Camera with VVX 500 and 600 Phones](#)
- [Changing Video Call Settings](#)
- [Place a Video Call on VVX 500, 600, and 1500 Phones](#)
- [Managing Video Calls without a VVX Camera on VVX 500 and 600 Phones](#)
- [Place Audio-Only Calls](#)

Tips for Video Calls

Use these tips when you're in a video call:

- Check your video image to make sure it's clear, bright, and sharp. For information on adjusting camera settings, see [Change Video Clarity](#).
- Avoid bright lights or windows behind you. If the camera faces a window or bright lights, you may have to adjust the camera settings. To adjust camera settings, see [Changing Video Call Settings](#).
- Avoid wearing bright colors, all-light or all-dark clothing, or busy patterns, such as small checks or narrow stripes. Pastels and muted colors look best on the screen.
- Use natural gestures and speak in a natural tone without shouting.
- Pause between sentences to allow for possible audio delay.
- During a conference call, mute your microphone when not speaking.
- Avoid tapping or rustling papers near the microphone.



Web Info: Video conferencing etiquette

For more tips on proper video conferencing etiquette, see Polycom's [The Etiquette of Video Conferencing and Telepresence](#).

Using a VVX Camera with VVX 500 and 600 Phones

With the Polycom VVX Camera attached to your phone, you can transmit video to contacts during calls. VVX Cameras are compatible with VVX 500 and 600 phones running UC software 4.1.3 or later. For information on attaching the VVX Camera to your phone, see the *VVX Camera Quick Start Guide* on the [VVX Camera Support](#) page. Check with your system administrator to make sure your phone has the correct software and is enabled to handle video calls.

The following figure shows the VVX 500 phone with a VVX Camera attached.

VVX 500 phone and VVX Camera



After the camera is attached to your phone, a message indicating that your camera firmware is updating and syncing with your phone displays. Do not remove the camera during this process. After your phone and camera sync, the message “Camera ready” is displayed, and your camera is ready to use.



Troubleshooting: Why is my phone not detecting my VVX Camera?

If your phone does not detect the VVX Camera when you attach it to your phone, the USB port on your phone may be disabled. Contact your system administrator and view the section [USB Port Issues](#) for more information.

Control the Lens Angle

On your VVX Camera, you can control the lens angle for video calls.

To control the lens angle for video calls:

- » On the top of the camera, slide the Lens Adjuster backward or forward slowly until the camera is at the desired angle.

Use the Privacy Shutter

You can use the privacy shutter on the VVX Camera to stop transmitting video during a call.

To use the privacy shutter:

- » On the side of the camera lens, rotate the Privacy Shutter Adjuster from the left to the right.

Status Indicators and Messages for the VVX Camera

This section includes the status indicators and messages that display on your phone for the VVX Camera connected to your VVX 500 or VVX 600 phone.

VVX Camera LED Indicators

LED State	Phone State
No LED	One of the following: <ul style="list-style-type: none"> • Phone has no power • Camera shutter is closed
Flashes red and green	Camera is booting up
Flashes amber and green	Camera firmware is updating
Flashes green	Incoming video call
Green	Video call is connected
Amber	One of the following: <ul style="list-style-type: none"> • Incoming call (no video or audio-only) • Outgoing call • Audio call is connected • Video is muted • Held call • Camera shutter is open, but video is not enabled and camera is not selected

VVX Camera Messages

Message	Action
VVX Camera attached. Firmware sync in progress, do not remove camera.	
VVX Camera firmware sync complete. Camera ready.	Indicates that your camera is ready to use.
VVX Camera firmware sync complete. Contact administrator to enable video.	
VVX Camera firmware sync complete. Camera rebooting.	
VVX Camera firmware sync complete. Video available when next idle.	
VVX Camera attached, camera ready.	Indicates that your camera is ready to use.

Your camera is during this process receive a message "complete" or "u

Indicate your phone Contact

Indicate your car

Indicates that y video call.

VVX Camera Messages

VVX Camera attached. Contact administrator to enable video.	
VVX Camera attached. Video available when next idle.	Indicates that your camera is ready to use for your next video call.
VVX Camera removed.	Indicates that you have detached your camera from your phone.
VVX Camera is not connected	Indicates that a VVX Camera is not attached to your phone, but you are accessing a feature or function that requires that the camera be attached.

Indicates that your phone isn't connected to the system. Contact your system administrator.

Changing Video Call Settings

When you update video settings, you change the way all video calls display on your VVX 500, 600, or 1500 phone. If you update settings during a call, the new settings apply to the next call and not the current call.

You can update the following video settings on your phone:

- [Set the Call Rate for Video Calls](#)
- [Stop Video for All Calls](#)
- [Change Video Clarity](#)
- [Changing the Video Call and PIP Displays](#)

Set the Call Rate for Video Calls

You can set the maximum call rate to use for a video call. The call rate you select applies to your next video call. Your system administrator can set a maximum call rate for video calls. If your system administrator sets a call rate limit, you cannot select a call rate above this limit.

To set the maximum call rate to use for video calls:

- 1 Navigate to **Settings > Basic > Call Rate**.
For VVX 1500 phones, navigate to **Menu > Settings > Basic > Call Rate**.
- 2 From the **Call Rate** screen, select the maximum call rate you want to use for video calls. You can choose a call rate between 128 kbps and 768 kbps. The default setting is 512 kbps.

Stop Video for All Calls

You can stop your phone from automatically transmitting your video at the start of all calls by disabling the Auto Start Video Tx setting. The default setting is enabled, which automatically transmits video at the start of every call.



Note: Does stopping video create an audio-only call?

Stopping video doesn't create an audio-only call. Even if you stop video, video information is still transmitted to the far side as a still picture, and the call is still a video call. To dial an audio-only call, see [Place Audio-Only Calls](#).

To disable the transmission of your video for all calls:

- 1 Navigate to **Settings > Basic > Video > Video Call Settings**.
For VVX 1500 phones, navigate to **Menu > Settings > Basic > Video > Video Call Settings**.

- 2 From the **Video Call Settings** screen, select **Auto Start Video Tx > Disabled**.

When disabled, your phone does not automatically transmit video at the start of all calls, and the No Video icon  is displayed next to your video during video calls.

Change Video Clarity

You can change the clarity of your video, including the brightness, contrast, and sharpness of your video stream. If your camera faces a bright light source, such as a bright window, you may need to increase the camera's brightness, contrast, and sharpness levels so the far side can see you better. To see how you look to the far side, view the picture-in-picture (PIP). See the section [Changing the Video Call and PIP Displays](#) for more information on the PIP.

You can adjust the clarity of your video using the following settings:

- *Target Frame Rate* Sets how smoothly your video displays. You can set a rate between 5 (least smooth) and 30 (smoothest). The default rate is 25.
- *Brightness Level* Sets how brightly your video displays. You can set a level between 0 (dimmiest) and 6 (brightest). The default level is 3.
- *Saturation Level* Sets how much color your video displays. You can set a level between 0 (lowest) and 6 (highest). The default level is 3.
- *Contrast Level* Sets the difference in brightness between the light and dark areas of your video. You can set a level between 0 (no contrast increase) and Auto (noise reduction contrast). The default level is 0.
- *Sharpness Level* Sets the clarity of detail in your video. You can set a level between 0 (lowest) and 6 (highest). The default level is 3.
- *Flicker Avoidance* Adjusts the flickering of your video captured by the camera sensor. You can select **50 Hz** (flicker avoidance for Europe and Asia) or **60 Hz** (flicker avoidance for North America). The default is 50 Hz.

To change the clarity of your video:

- 1 Navigate to **Settings > Basic > Video > Camera Settings**.
For VVX 1500 phones, navigate to **Menu > Settings > Basic > Video > Camera Settings**.
- 2 From the **Camera Settings** screen, select and adjust the desired camera settings.

Changing the Video Call and PIP Displays

You can set up your phone so that it displays all video during calls in specific ways. You can choose to do the following:

- Display all incoming video calls on the full screen
- Change the way video displays
- View full-screen video with or without the PIP
- Display the PIP next to, or over, full-screen video

Your video image is displayed at the top-right of the screen in a picture-in-picture (PIP) video, as shown next. The PIP is displayed on your Home screen and during video calls.

Picture-in-Picture video on the Home screen



When you're in a call with a person that has video-enabled, your video is displayed in the PIP, and the person you're talking with (the far-side) is displayed in the Active Call screen.

Call window with PIP and far-side video



You can customize how and where you see your PIP video and the far-side video. For example, you can swap the windows in which the video is displayed, or even start and stop the transmission of your video. The following sections show you how to customize video on your phone.



Note: The way far-side video is displayed on your phone may vary

Depending on the phone or system that is sending video, black bars might appear on the top, bottom, or sides of the video image. This occurs because the aspect ratio of the video received does not match the display area on your phone, and the portions of the video that are not being received display as black bars. If the received video matches your phone's display area, the received video fills the screen. If black bars display, you can remove them by selecting cropped video screen mode (see [Change How Far-Side Video Displays](#)).

Change How PIP Video Displays

You can update the way the PIP is displayed when you're in full screen mode, when you view the far-side, or when you view your video on the full screen. You can change the following PIP settings:

- *Local Camera View(Full Screen)* Enables or disables the PIP from displaying when you view video on the full screen. The default setting is Enabled.

- **Local Camera View Mode (Full Screen)** Sets whether you want the PIP to display over, or next to, full-screen video. The default setting is Side-by-Side. You can choose to enable one of these settings:
 - **Side-by-Side** Displays the PIP next to, rather than over, full-screen video.
 - **PIP** Displays the PIP over full-screen video.

To change the way the PIP is displayed:

- 1 Navigate to **Settings > Basic > Video > Local Camera View**.
For VVX 1500 phones, navigate to **Menu > Settings > Basic > Video > Local Camera View**.
- 2 From the **Local Camera View** screen, select and adjust the PIP settings.
- 3 Select **Save**.

Change How Far-Side Video Displays

You can adjust the appearance of the far-side video so that it displays as one of the following:

- **Normal** The video image displays with correct proportions. Black bars appear on the top, bottom, or sides of the area to maintain the correct aspect ratio if the aspect ratio of the received video does not match the display area on your phone. The portions of the video that are not being received display as black bars.
- **Full** If the received video image is not the same aspect ratio as the phone's display area, the video image is stretched to fill the area. If the aspect ratios match, no stretching occurs.
- **Crop** The video image is resized to maintain the correct aspect ratio. Any parts of the image that do not fit within the area are cropped.

You can choose to apply the following settings for video that displays on the full screen and in the Active Call screen:

- **Video Screen Mode (Window)** Adjusts the video image that displays in the Active Call screen. You can select Normal, Full, or Crop. The default setting is Normal.
- **Video Screen Mode (Full Screen)** Adjusts the video image that displays on the full screen. You can select Normal, Full, or Crop. The default setting is Normal.

The following pictures show how normal, full, and cropped modes display in the Active Call screen.

Far-side video display settings

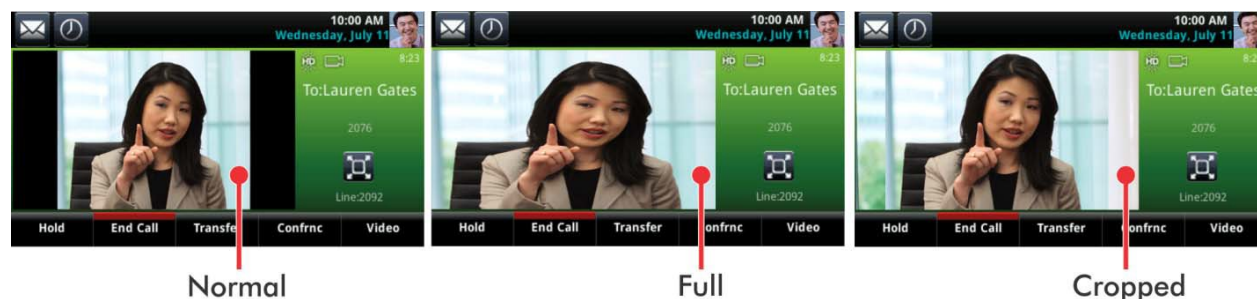

To change the way far-side video displays:

- 1 Navigate to **Settings > Basic > Video > Video Screen Mode**.
For VVX 1500 phones, navigate to **Menu > Settings > Basic > Video > Video Screen Mode**.

- 2 From the **Video Screen Mode** screen, select and adjust the video screen settings.
- 3 Select **Save**.

Display All Video Calls in Full Screen Mode

By default, the far-side video always displays in the Active Call screen. You can enable your phone to display all incoming videos on the full screen.

To display all incoming video in full screen:

- 1 Navigate to **Settings > Basic > Video > Video Call Settings**.
For VVX 1500 phones, navigate to **Menu > Settings > Basic > Video > Video Call Settings**.
- 2 From the **Video Call Settings** screen, select **Auto Video Full Screen > Enable**.
When enabled, this setting automatically enables your phone to display far-side video in full screen. When disabled, far-side video is displayed in the smaller Active Call screen.
- 3 Select **Save**.

Place a Video Call on VVX 500, 600, and 1500 Phones

This section explains how to transmit video during a video call. During a video call, you can stop sending your video, swap video, or view full-screen video. All these actions affect only the call you're in and not future video calls. To customize video settings, see the section [Changing Video Call Settings](#).

To place a video call:

- 1 Tap **New Call**, enter a number or select a contact, and tap **Send**.
- 2 After your contact answers, press the **Video** or **Start Video** soft key.
Your camera transmits video to your contact. On phones with the VVX camera, the LED light is green when video is transmitting.

During a video call, including a conference call, a Video soft key is displayed. You can select this soft key to access video functions that can stop video transmission, display video in full screen, and swap the windows in which the video is displayed.

Stop Sending Video

You can stop transmitting video at any time during a call. For information on how to prevent video from transmitting for all calls, see the section [Stop Video for All Calls](#).

To stop sending video during a call:

- » Do one of the following:
 - Press the **Stop Video** or **Video Mute** softkey.
On VVX 500 and 600 phones with a VVX Camera, the LED light is amber when video is not transmitting.

- Close the Privacy Shutter.

On VVX 500 and 600 phones with a VVX Camera, no LED light shows when the shutter is closed.

The No Video icon  is displayed next to your PIP video and the far-side cannot see you.

Stopping video or closing the camera shutter does not create an audio-only call. Even if you stop video, video information is still transmitted to the far side as a still picture, and the call is still a video call. To dial an audio-only call, see [Place Audio-Only Calls](#).



Note: How can I stop far-side video?

You can't start and stop far-side video. If your phone is set up to receive far-side video, the far-side video always displays.

No Video from the Far Side

If the far side cannot send video, or stops sending video, a No Video icon is displayed on your phone, as shown in the next figure. If the far side is unable to send video, a thunderbolt icon is displayed next to the No Video icon, as shown next.

Call window with No Video icon



Indicates that the far side can't send video

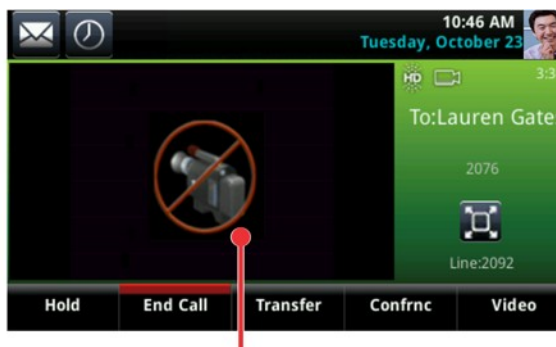

Indicates that the far side has stopped sending video



Note: Why do I see a different No Video icon?

Depending on the phone or system that has stopped sending video, you may see a different icon than the one shown above.

Display Video Calls in Full Screen

You can display the far-side video on the full screen, and your PIP continues to display in the corner with the soft keys hidden. In full screen, call details display along the bottom of the screen, including an icon that you can select to exit full screen mode. The following figure displays full screen video on the VVX 600 phone.

Full screen mode on VVX 600 phone

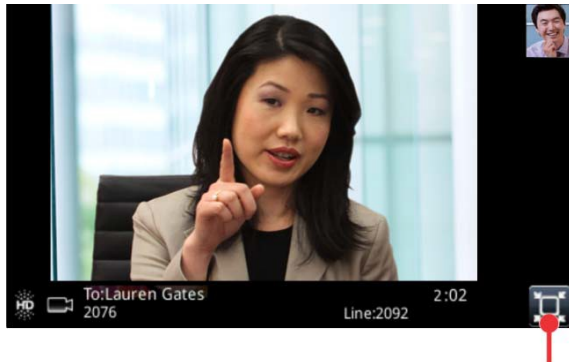

Tap to exit full screen mode



To view video in full screen:

- » Do one of the following:
 - Tap **Video > Full Screen**.
 - Tap the Full Screen icon .

Exit Full Screen View

You can exit full screen view and video in your default video display.

To exit full screen view:

- » Tap the Full Screen icon . If you don't see the Full Screen icon , press your finger at the bottom of the screen until it is displayed.

Swap Video

You can switch the locations of your video and the far-side video. If you do this, your PIP is displayed in the Active Call screen, and the far-end video, previously displayed in the Active Call screen, is displayed in the PIP location. When you swap video so that your video is displayed in the Active Call screen, rather than in the PIP, the message “Local camera” is displayed next to your video, as shown next.

Swapped video screens



To swap where video is displayed:

- » During a video call, do one of the following:
 - Tap **Video > Swap**.
 - Tap the PIP.

Handling Video and Audio Calls

When you have multiple calls, you can easily manage a video call from the Calls screen. In the Calls screen on VVX 500 and 600 phones, you can identify the video call by the video stream that is displayed next to the call's details. On VVX 1500 phones, the active video call is displayed on the Active Call screen, and all held calls display above the soft keys.

When two or more calls are video calls, only the active call displays video. On VVX 500 and 600 phones, all other video calls show a paused grayscale image of the far side taken just before the call was held, as displayed next. When you resume a held video call, the held call becomes active and displays video.

Multiple video calls on the Calls screen on the VVX 600 phone

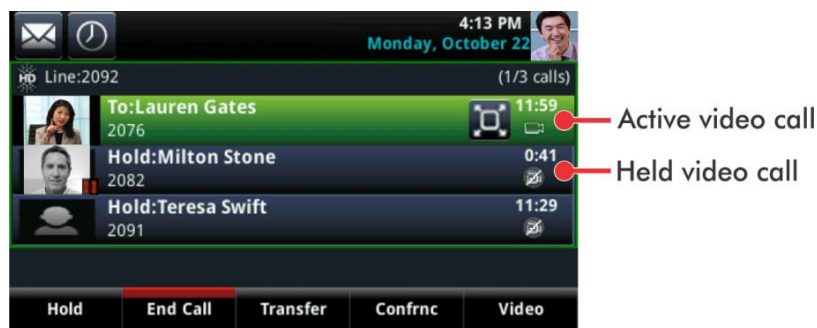

Handle Conference Calls with Video

When you set up a conference, your phone displays video for only one conference participant at a time, even if more than one participant can send video. The person whose video you see is the last person with video enabled who joined the conference. If you use the **Join** soft key to set up the conference, you see the video of the person who was held just prior to joining the conference.



Note: Is it possible to view all video participants?

Viewing all video participants requires the use of a Polycom Video Conference Bridge. For more information, contact Blulp.

When your system administrator enables the conference management feature on your phone, you can select whose video to see. For more information on managing conference participants, see [Manage Conference Call Participants](#).

To change which conference participant's video you see:

- 1 During a conference call, select **Manage**.
- 2 From the **Conference** window, select a contact and tap **Select Video**.

The person who previously displayed video is replaced with the person you selected.

The Select Video soft key does not display when you're currently exchanging video with the selected party, or when the party does not have video capability.

Managing Video Calls without a VVX Camera on VVX 500 and 600 Phones

When you do not have a VVX Camera attached to your VVX 500 or 600 phone, you can receive video, but you cannot send video. Video always displays when the person you are talking with can send video, and your phone is enabled to receive video.



Note: Video from different endpoints display differently on your phone

Depending on the phone or system that is sending video, black bars may appear on the top, bottom, or sides of the video image. This occurs because the aspect ratio of the sent video doesn't match the display area on your phone, and the portions of the video that aren't being received display as black bars. If the received video matches your phone's display area, the received video fills the screen. If black bars display, you can remove them by selecting the cropped video screen mode (see [Change How Far-Side Video Displays](#).)

Managing Audio and Video Calls

When you are in a call with a person who has a video-enabled device, the far-side video displays in the Active Call screen. You can view the far-side on the Calls screen as well. For more information on viewing and changing how the far-side video displays, see the sections [Change How Far-Side Video Displays](#) and [Display All Video Calls in Full Screen Mode](#).



Note: Why do I see a different No Video icon?

Depending on the phone or system that has stopped sending video, you may see a different icon than the one shown in the [Changing the Video Call and PIP Displays](#) section.

If you place a video call on hold, the person's video stream stops and is replaced by a paused grayscale image taken just before you held the call, as displayed next. The person's video stream returns when you resume the call.

Held video call

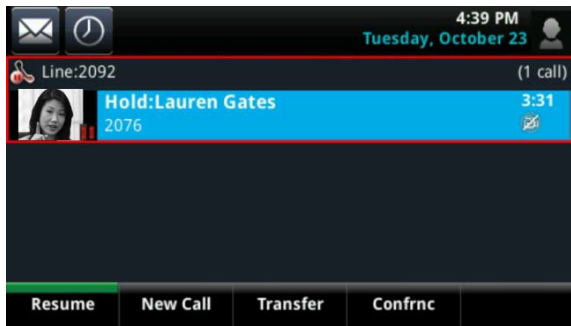

View Video in Full Screen during Calls

During a video call, you have the option of viewing video on the full screen instead of in the smaller Active Call screen. To set your video to display in full screen for all video calls, see the section [Display All Video Calls in Full Screen Mode](#).

To view full-screen video:

- » Do one of the following:
 - Tap the Full Screen icon .
 - Tap the video area to view video on the full screen.
 - Tap **Video**, and select **Full Screen**.

Full-screen video displays. Call details display at the bottom of the screen, along with an icon that you can select to exit full screen mode, as displayed next. The call details display for five seconds, and then disappear. To see the details again, tap the screen.

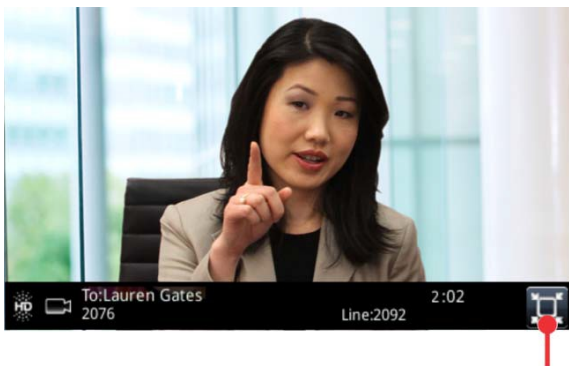

Tap to exit full screen mode



Tip: Can I automatically view all video calls in full-screen mode?

You can set up your phone to automatically display all video calls in full-screen mode. For more information, see the section [Display All Video Calls in Full Screen Mode](#).

Handling a Mixture of Video and Audio-Only Calls

When you have multiple calls, you can easily manage a video call from the Calls screen. From the Calls screen, you can quickly identify the video call by the video stream that is displayed next to the call details, as shown next.

Video calls on the Calls screen

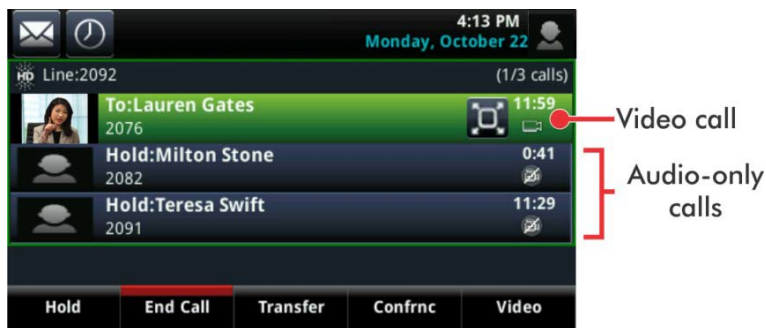

If two or more calls are video calls, only the active call shows a video stream of the far side. All other video calls show a paused grayscale image of the far side. If you resume a held video call, the held call becomes active and displays an active video stream again.

Place Audio-Only Calls

Your system administrator can determine how your phone handles audio and video. You can change the settings on your phone to handle audio and video calls in one of the following ways:

- *Video-enabled* All calls you place or answer are video calls. This means that the person you call sees your video on his or her phone, and you see video on your phone from the other person on the call.
- *Audio only* All calls are audio only and do not display video information. Your phone screen does not display video in the Active Call screen, and you do not have the option to send video. If the person you call sends video, you do not see them.
- *Video and Audio* You have the option to choose a call mode, either video or audio-only. If this option is set up on your phone, you can choose the call mode on a call-by-call basis, as well as choose a mode to apply to all the calls you place.

To choose audio-only for all your calls:

- 1 Navigate to **Settings > Basic > Video > Video Call Settings**.
On VVX 1500 phones, navigate to **Menu > Settings > Basic > Video > Video Call Settings**.
- 2 From the **Video Call Settings** screen, select **Default Call Mode**, and select **Audio Only**.
The mode you choose applies to your next call and all subsequent calls.

Manage Call Lists and Directories

All VVX phones support a Recent Calls list, a Contact Directory and a Corporate Directory. The phones can also support a BluIP Directory if enabled by your system administrator. This section describes each of these in the following topics:

- [View Recent Calls](#)
- [Managing the Contact Directory](#)
- [Managing the Corporate Directory](#)
- [Search the Outlook Directory](#)
- [Searching the BluIP Directory](#)



Note: Feature availability

Your phone may not support all of the features described in this section. Check with your system administrator to find out which features are available on your phone.

View Recent Calls

All VVX phones maintain a Recent Calls list that includes missed, received, and placed calls. Each list holds up to 100 entries.

You can perform the following tasks from the Recent Calls list:

- Sort, order, and filter calls. By default, the list displays all call types with the most recent call displaying first.
- Remove calls from the list.
- Select a call record to view call details.
- Select a call record to automatically call a contact.

To view your Recent Calls list:

- » Navigate to **Directories > Recent Calls**.



On VVX 1500 phones, press the **Directory** key and tap **Call Lists**.



Tip: Quickly accessing the Recent Calls list on VVX 500 and 600 phones

To quickly access recent calls, tap the RecentCalls icon  in the status bar.

The following icons display next to a call to indicate the call type:

-  Indicates a placed call
-  Indicates a received call
-  Indicates a missed call

View Call Details

In the Recent Calls list, you can view call details, edit call details before calling a contact, save a contact to your directory, and delete call entries.

To view call details:

- » Select **Info** or tap the Info icon  next to a call record.

Save a Recent Contact

From the Call Details screen, you can save a contact to the Contact Directory.

To save a contact to your Contact Directory:

- » From the **Call Details** screen, select **Save**.
If the person is already in your Contact Directory, but is not a favorite, **Add to Favorites** is displayed.

Delete a Contact

You can delete contacts from the Recent Calls list.



To delete a contact from the Recent Calls list:

- » Select **Delete** or tap the Delete icon .

Edit Recent Contact Entries

You can edit a contact's phone number stored in your Recent Calls list before returning the contact's call.

To edit a recent contact's number before calling the contact:

- 1 Select **Edit** or tap the Edit Number icon .
- 2 Edit the number, and select **Dial** or tap the Dial icon .

Sort Recent Call Entries

You can customize the Recent Calls list to view calls by call type, time, and call name.

When you sort calls by the time of the call, you can order them in ascending (oldest call first) or descending (most recent call first) order. When you sort calls by name, you can order them in ascending (alphabetical) or descending (reverse-alphabetical) order.

To sort Recent Calls entries by time or call name:

- 1 Select **Sort** or tap the Sort icon .
- 2 Under **Sort**, choose **Time** or **Name**.
- 3 Under **Order**, choose **Ascending** or **Descending**.

Sort Entries by Call Type

When you filter calls, you can choose to display only missed, received, or placed calls. Or, you can choose to display all call types (the default).

To sort Recent Call entries by call type:

- 1 Select **Type** or tap the Filter icon .
- 2 Choose **Missed Calls**, **Received Calls**, or **Placed Calls**.



Note: About filtered call lists

You cannot save your filtered call list results. If you filter your Recent Calls list so that only a certain call type displays, the next time you display the list, all call types display in the default filter.

Managing the Contact Directory

You can store a large number of contacts in your phone's Contact Directory. Contact your administrator for the exact number of contacts available on your phone.

You can perform the following tasks in your Contact Directory:

- [Search for Contacts](#)
- [Add a Contact to the Contact Directory](#)
- [View Contact Information](#)
- [Update a Contact's Information](#)
- [Delete a Contact](#)

Search for Contacts

In the Contact Directory, you can enter a search criteria to find your desired contact.

To search for a contact:

- 1 Navigate to **Directories > Contact Directory**.
On VVX 1500 phones, press the **Directory** key and tap **Contact Directory**.
- 2 In the **Contact Directory**, select **Search**.
- 3 From the **Search** screen, enter your search criteria and select **Search**.

If you're using the onscreen keyboard on VVX 500, 600, and 1500 phones, tap the Okay icon  then **Search**.

A list of search results is displayed.

Add a Contact to the Contact Directory

When you add a contact to your Contact directory, you can choose how much information you want to enter for your contact. You are required to only enter a contact number for each new contact.

The following is a list of information you can enter for each contact:

- *First and Last Name* The name of your contact.
- *Contact* Your contact's phone number.
- *Job Title* Your contact's position.
- *Email* A personal or work email address.
- *Favorite Index* An index number that displays in your Favorites list. For more information about favorites, see [Managing Favorites](#).
- *Label* A label or title for your contact.



Note: Directory Fields are Administrator-Set

If your phone does not display all the above mentioned contact fields, see your system administrator. The only required field in the Contact Directory is the Contact field, which includes the contact's phone number.

To add a contact to your Contact Directory:

- 1 In the **Contact Directory**, select **Add** or tap the Add icon .
- 2 From the **Add Contact** screen, enter your contact's information in the available fields.
You are required to only enter a number in the **Contact** field when adding a new contact to the directory. You can choose to enter additionally information.
- 3 Select **Save**.



Tip: Saving contacts from the Recent Calls list and Corporate Directory to your Contact Directory

To save a recent caller to your Contact Directory, see [View Recent Calls](#).

If a Corporate Directory is available on your phone, you can add contacts from the Corporate Directory to your Contact Directory. For information, see [Managing the Corporate Directory](#).

View Contact Information

From your Contact Directory, you can view information for any contacts saved to the directory.

To view contact information:

- 1 Navigate to **Directories > Contact Directory**.
On VVX 1500 phones, press the **Directory** key and tap **Contact Directory**.
- 2 In your **Contact Directory**, select a contact.
The **Contact Information** screen is displayed with the contact's name and phone number. Additional information, such as a job title, label, or email address, can also display.

Update a Contact's Information

After you add a contact to your Contact Directory, you can update the contact's information.

To update a contact's information:

- 1 From the **Contact Directory**, select a contact.
- 2 From the **Contact Information** screen, select **Edit** or tap the Edit icon .
- On VVX 101, 201, 300/310 and 400/410 phones, select **Info > Edit**.
- 3 From the **Edit Contact** screen, update the contact's information.
- 4 Select **Save**.

Delete a Contact

You can delete any contact from the Contact Directory.

To delete a contact:

- 1 From your **Contact Directory**, select a contact.

- 2 From the **Contact Information** screen, select **Delete** or tap the Delete icon .
On VVX 101, 201, 300/310 and 400/410 phones, select **Info > Delete**.
A confirmation message is displayed, confirming that you want to delete the contact.
- 3 Select **Yes** to delete the contact.

Managing the Corporate Directory

Your system administrator can set up your phone so that you can access a Corporate Directory. However, you cannot update your Corporate Directory, and your administrator determines which contacts you can see. Check with your system administrator to find out if this feature is available on your phone.

You can do the following in the Corporate Directory:

- [Searching the Corporate Directory](#)
- [Add Contacts to the Contact Directory](#)
-

Searching the Corporate Directory

In the Corporate Directory, you can perform a quick or advanced search of contacts.

Perform a Quick Search

A quick search enables you to search for contacts using either their first name, last name, or by typing a few letters in their name.

To perform a quick search of the Corporate Directory:

- 1 Navigate to **Directories > Corporate Directory**.
On VVX 1500 phones, press the **Directory** key, and tap **Corporate Directory**.
By default, a blank search screen is displayed.
- 2 From the **Corporate Directory**, enter the first few characters of the contact's first or last name, and select **Submit**.
The screen displays a list of contacts, starting with the most successful matches.
- 3 Select a contact and select **View** to view the contact's information.

Perform an Advanced Search

An advanced search enables you to choose to search for contacts by first name, last name, or phone number.

To perform an advanced search:

- 1 Navigate to **Directories > Corporate Directory**.
On VVX 1500 phones, press the **Directory** key, and tap **Corporate Directory**.
By default, a blank search screen is displayed.
- 2 In the **Corporate Directory**, select **AdvFind**.

- 3 From the **Advanced Find** screen, enter your search criteria, and select **Submit**.
The screen displays a list of contacts, starting with the most successful matches.
- 4 Select a contact and select **View** to view the contact's information.

Save Search Results

You can save your last search results so that the next time you view the Corporate Directory, the results of your last search is displayed.

To save Corporate Directory search results:

- 1 Navigate to **Settings > Basic > Preferences > Corporate Directory > View Persistency**.
On VVX 1500 phones, navigate to **Menu > Settings > Basic > Preferences > Corporate Directory > View Persistency**.
- 2 From the **View Persistency** screen, select **Enabled**.
Each time you view the Corporate Directory, your last search results automatically display.

Clear Search Results

After you search for a contact, you can clear your search results and start a new search.

To clear your search criteria:

- » On the **Search** screen, select **Clear**.

Add Contacts to the Contact Directory

You can add contacts in the Corporate Directory to your Contact Directory. When you save a Corporate Directory contact to the Contact Directory, the first name, last name, and phone number of the contact are saved to the Contact Directory. You can go to the Contact Directory to see if the contact was saved correctly and to add additional contact information. See the section [Managing the Contact Directory](#) for information on viewing and editing contacts.

To add a contact to your Contact Directory:

- 1 From the **Corporate Directory**, search for a contact.
- 2 From the search results, select the contact, and select **View**.
- 3 From the **Contact Information** screen, select **Save**.

Search the Outlook Directory

You can search for Microsoft Outlook contacts on your phone.

This feature is not available for VVX 101 and 1500 phones. Check with your system administrator to find out if this feature is available on your phone.

To search for Outlook contacts on your phone:

- 1 Navigate to **Directories > Outlook Search**.

- 2 Enter your contact's first or last name. If you're using the onscreen keyboard on VVX 500 and 600 phones, tap the Okay icon  after you have entered your contact's information.

Your contact and similar contacts are displayed automatically as you type your contact's information.

Save Outlook Contacts to the Contact Directory

You can save Outlook contacts to the Contact Directory on your phone.

The first name, last name, and phone number of the contact are saved to the Contact Directory. You can go to the Contact Directory to see if the contact was saved correctly and to add additional contact information. See the section [Managing the Contact Directory](#) for information on viewing and editing contacts.

To save Outlook contacts:

- 1 Search for your contact.
- 2 Select your contact.
- 3 Select **Add to Contacts**. If you do not see the Add to Contacts soft key, select the **More** soft key.

Searching the BluIP Directory

You can access and search the BluIP Directory on your phone, and you can choose to perform a simple or advanced search for contacts.

The BluIP Directory is not supported on VVX 101, 201, and 1500 phones. Check with your system administrator to find out if this feature is available on your phone.

Perform a Simple Search

A simple search enables you to search for contacts using either their first name, last name, or by typing a few letters in their name.

To perform a standard search:

- 1 Navigate to **Directories > BluIP Directory**. A search screen is displayed.
- 2 Enter your search criteria, and select **Submit**.

Your search results display. The number of records that match your search criteria is displayed for one second above the soft keys. A maximum of 50 contacts are available for viewing at one time.



Troubleshooting: Errors when accessing the BluIP Directory

If the BluIP Directory cannot be reached, the message "Server Unavailable" is displayed. Contact your system administrator.

Perform an Advanced Search

An advanced search enables you to choose to search for contacts by first name, last name, or phone number.

To perform an advanced search:

- 1 Navigate to **Directories > BluIP Directory**. A search screen is displayed.

- 2 Select **Advanced Search** in the BluIP Directory. The Advanced Search screen is displayed.
- 3 In the **Advanced Search** screen, choose to search for a contact by first name, last name, or a contact number.
- 4 Enter your search criteria, and select **Submit**. Your search results is displayed.
- 5 Choose your contact. A contact details screen is displayed, as shown next.



Add BluIP Contacts to the Contact Directory

After you find your BluIP contact, you can add the contact to your Contact Directory on your phone.

The first name, last name, and phone number of the contact are saved to the Contact Directory. You can go to the Contact Directory to see if the contact was saved correctly and to add additional contact information. See the section [Managing the Contact Directory](#) for information on viewing and editing contacts.

To add a BluIP contact to the Contact Directory

- » In the contact details screen, select **Add to local directory**.

Manage Buddy Lists, Favorites, and Contact Lists

On your VVX phone, you can add contacts as favorites, view and manage BluIP UC-One contacts, and watch contacts in your Buddy list. This section includes the following topics:

- [Managing Favorites](#)
- [Using Buddy Lists](#)
- [Managing BluIP UC-One Favorites and Contacts](#)



Note: Feature availability

Your phone may not support all of the features described in this section. Check with your system administrator to find out which features are available on your phone.

Managing Favorites

Favorites are the contacts in your Contact Directory that you will call most often. You can add contacts as favorites from the Contact Directory, designate an index number for favorites, view favorites on the Home or Lines screen depending on your phone, and delete favorites.

Add Favorites

Contacts that you add as favorites display on the Home screen on VVX 1500 phones, in the Lines screen on other VVX phones, and in the Favorites list on all VVX phones. On VVX 101, 201, 300/310, 400/410, 500, and 600 phones, a star is displayed for contacts saved as favorites.

To add a contact as a Favorite:

- 1 Navigate to **Directories > Contact Directory**.
On VVX 1500 phones, press the **Directory** key, and select **Contact Directory**.
- 2 From your **Contact Directory**, select a contact.
- 3 Select **Add** or **Add to Favorites**.
A notification is displayed asking if you want to automatically accept the next available index number, or manually enter your own.
- 4 Select **Yes** to automatically accept an index number or select **Edit Index** to enter a unique index number.
You can enter a number up to 99 for VVX 101 and 201 phones or 9999 for all other VVX phones.

View Favorites

You can view favorites in your Favorites list in the Directory or the New Call screen. Favorites display consecutively according to their index number. The contact with the lowest number is displayed first. To reorder your favorites, see the section [Reorder Favorites](#).

To see your Favorites list:

- » Select **New Call > Favorites**.

View Favorites on the Home Screen

On VVX 1500 phones, favorites display on the Home screen below the phone number. On VVX 500 and 600, you tap the phone line to view favorites from the Home screen. You cannot view favorites from the Home screen on VVX 101, 201, 300/310, and 400/410 phones.

To view favorites from the Home screen on VVX 500 and 600 phones:

- » From the **Home** screen, tap the phonenumber.

View Favorites from the Lines Screen

You can view a list of favorites on the Lines screen on all VVX phones, not including VVX 1500 phones.

To see your favorites from the Lines screen:

- » From the **Home** screen, press the Home key .

Reorder Favorites

You can change the order in which your favorites display on the Home or Lines screen.

To reorder your favorites:

- 1 From your **Contact Directory**, select a contact.
- 2 From the **Contact Information** screen, select **Edit** or tap the Edit icon .
- 3 From the **Edit Contact** screen, select **Favorite Index**, and enter a new favorite index number.
- 4 Select **Save**.

Delete Favorites

You can delete favorites to make room for new favorites.

To delete a favorite:

- 1 From your **Contact Directory**, select the contact.
- 2 From the **Contact Information** screen, select **Edit** or tap the Edit icon .
- 3 From the **Edit Contact** screen, select **Favorite Index**, and delete the favorite index number.

4 Select **Save**.



Tip: Quickly deleting a favorite

From the Lines screen, press and hold the favorite until the Contact Information screen is displayed. Select **Delete** or tap the Delete icon . The contact remains in your directory, but is no longer a favorite.

Using Buddy Lists

A Buddy list is a list of users whose status or presence you can monitor. Users can update their presence setting to status such as Be right back, Out to lunch, or Busy, and you can view their status in real time from your Buddy list. You can also view your buddies' status from the Lines and Home screens, if your buddy is a favorite.

In this section, you'll learn how to:

- [Add Contacts to Your Buddy List](#)
- [Monitor Contacts on Your Buddy List](#)
- [View Watcher List](#)
- [Block Contacts from Viewing Your Status](#)

Add Contacts to Your Buddy List

If you want to monitor other people, you need to make sure they are in your Buddy list. You add people to your Buddy list from your Contact Directory, so you must first add them to your Contact Directory before adding them to your Buddy list. For information on adding a person to your contact directory see the section [Managing the Contact Directory](#).

To add a contact to your Buddy list:

- 1 From your **Contact Directory**, select a contact.
- 2 From the **Contact Information** screen, select **Edit** or tap the Edit icon .
- 3 From the **Edit Contact** screen, select **Watch Buddy > Enabled**.
The default setting is Disabled. When enabled, the contact is added to your Buddy list so you can monitor the contact's status.
- 4 Select **Save**.

View Your Buddy List

When you enable the Watch Buddy setting for a contact, the contact is displayed in your Buddy list.

To view your Buddy list:

- » From the Lines screen, select **Buddies**.



Tip: Dialing buddies





You can quickly dial a buddy from your Buddy list. From the Lines screen, select **Buddies**, select the buddy you want to call, and select **Dial** or tap the Dial icon .

Monitor Contacts on Your Buddy List

You can monitor your buddies from your Buddy list. If a buddy is a favorite, you can also monitor the buddy from the Home and Lines screen.

Your buddies display an icon next to their name to indicate their status. The following table shows the general icons and the status they represent. See the section [Understanding Phone Icons and Status Indicators](#) for differences in presence icons between phones.

Buddy Status and Icons

Buddy Status	Icon
Available	
Busy	
Away	
Do Not Disturb	
Offline	

To monitor your buddies from the Buddy list:

- » Do one of the following:
 - Select **Buddies** or navigate to **Settings > Features > Presence > Buddy Status**.
On VVX 1500 phones, navigate to **Menu > Features > Presence > Buddy Status**.
 - From the **Home** screen, press the Home key .

View Watcher List

Contacts who can monitor your status are added to the Watcher list.

To display contacts that can view your status:

- » Navigate to **Settings > Features > Presence > Watcher List**.
On VVX 1500 phones, navigate to **Menu > Features > Presence > Watcher List**.
A list of contacts that can monitor your status is displayed.

Block Contacts from Viewing Your Status

You can prevent someone from monitoring you by blocking the contact in your Contact Directory. If you unblock the contact, the contact can add you to their Buddy list and monitor you.

To block a contact from viewing your status:

- 1 From your **Contact Directory**, select a contact.
- 2 From the **Contact Information** screen, select **Edit** or tap the Edit icon .
- 3 From the **Edit Contact** screen, select **Block Buddy > Enabled**.

The default setting is Disabled. When enabled, the contact cannot watch your status, and the contact is displayed in your Blocked List.

- 4 Select **Save**.

View Blocked List

Contacts who cannot monitor your status are added to the Blocked List.

To display contacts that cannot view your status:

- » Navigate to **Settings > Features > Presence > Blocked List**.
On VVX 1500 phones, navigate to **Menu > Features > Presence > Blocked List**.
A list of contacts that cannot monitor your status is displayed.

Unblock a Contact

From the Blocked list, you can unblock contacts and allow them to monitor your status.

To unblock a contact:

- 1 Navigate to **Settings > Features > Presence > Blocked List**.
On VVX 1500 phones, navigate to **Menu > Features > Presence > Blocked List**.
- 2 From the **Blocked List** screen, select a contact.
- 3 Select **Unblock**.

The contact can now monitor your status and is displayed in the Watcher list.

Managing BluIP UC-One Favorites and Contacts

You can see your BluIP UC-One contacts marked as favorites in the UC-One Contacts list and on the Lines screen on your phone.





The VVX 101, 201, and 1500 phones do not support BluIP UC-One favorites. Contact your system administrator to find out if this feature is available on your phone.

View BluIP UC-One Contacts' Presence Information

UC-One contacts are Enterprise Directory contacts that have Instant Messaging and Presence (IM&P) enabled, and you can view their presence information on your phone. While you can view UC-One contacts presence information on the Lines screen, you cannot change your presence status on the phone. You can change your presence status only in the BluIP UC-One client on your computer.

The following table shows the presence icons that display for BluIP UC-One contacts on your phone.

BluIP UC-One Contact Presence Icons

Icon	Description
	Visible
	Away
	Do Not Disturb
	Invisible, Offline, Unknown

View BluIP UC-One Contacts and Favorites

In addition to viewing UC-One contacts with presence information, you can also view other UC-One contacts marked as favorites on the Lines screen. UC-One favorites who do not have Instant Messaging and Presence (IM&P) enabled do not display presence information on your phone and instead display with a flying handset icon .

You cannot mark UC-One contacts as favorites on your phone. You must mark contacts as favorites in the BluIP UC-One client on your computer. Contacts marked as favorites in the BluIP UC-One client display on your phone after one minute.

To view BluIP UC-One contacts and favorites on the Lines screen:

- » From the **Home** screen, press the **Home** key.

UC-One contacts and favorites display on the Lines screen, as shown in the following figure.



You can also call BLUIP Favorites from the Lines screen by selecting a contact.

View Favorites in the Contact List

In addition to viewing UC-One favorites on the Home screen, you can also view your favorites in the UC-One Contacts list.

To view BLUIP UC-One favorites from the UC-One Contacts List:

- 1 Select **Directories > UC-One Contacts**.
- 2 Select the group name to view the list of contacts for that group.

In the example shown below, the green star indicates that Chris and Alfred are UC-One favorites.



Filter Favorites

You can filter your list of contacts either by Favorites or by status.

To filter BLUIP UC-One favorites:

- 1 Select **Directories > UC-One Contacts**.
- 2 Select **Filter** or tap the Filter icon .
- A filter selection screen is displayed.
- 3 Choose your desired filter selection:
 - If you select **Favorites**, only your BLUIP UC-One Favorites display on the Home screen and in the UC Contacts list.

- If you select **Online**, only the BluIP UC-One contacts that are currently online display on the Home screen and in the UC Contacts list.

View Contacts and Groups

You can access your BluIP UC-One contacts and groups on your phone, but you cannot create new groups, delete existing groups, or move contacts from one group to another on your phone. You can alter groups only in the BluIP UC-One client on your computer.

To view the BluIP UC-One contacts:

- 1 Select **Directories > UC-One Contacts**.

Your UC-One contacts display by groups. Contacts display under the **All Contacts** group if there are no user-defined groups.

- 2 Choose a group and select your contact.

The contact screen is displayed.



Troubleshooting: An error message is displayed when I try to view my UC-One contacts

If the message “Authentication failure” is displayed when you try to view UC-One contacts, make sure you entered the correct BluIP UC-One credentials on your phone. See the section [Sign In Using Your BluIP UC-One Credentials](#) for more information.

Search for BluIP UC-One Contacts

You can search for UC-One contacts from the UC-One Contacts screen.

To search for BluIP UC-One contacts from the UC-One Contacts screen:

- 1 Select **Directories > UC-One Contacts**.
- 2 Select **Search** or tap the Search icon .

A search field is displayed, as shown next.



- 3 Enter your contact's first or last name.
A list of search results display.



Web Info: Additional information on using BLuIP applications

For information on using BLuIP applications, refer to the following resources:

- [BLuIP UC-One](#)
- [BLuIP Instant Messaging & Presence](#)

Update Your Presence Status

Polycom phones enable you to sign into your personal communication software client and update your presence status on your phone. This chapter provides information on how to update your Buddy status on VVX phones.

**Note: Feature availability**

Your phone may not support all of the features described in this section. Check with your system administrator to find out which features are available on your phone.

Update Your Buddy Status

You can update your status on your phone so that contacts can monitor your status from their phones. Your updated status is displayed in the status bar on your phone, and your contacts are automatically notified of your new status.

You can update your status to one of the following:

- Online
- Busy
- Be right back
- Away
- On the phone
- Out to lunch
- Do not disturb

Your phone also sends certain status information to the people watching you automatically—such as if you are in a call, if you enabled Do Not Disturb on your phone, or if your phone is offline because you restarted it.

**Note: Your presence status changes when you enable and disable the Do Not Disturb feature**

If you select the status option Do Not Disturb, and enable or disable the Do Not Disturb feature on your phone, your status changes to Online.

To update your presence setting:

- 1 Select **My Status**, or navigate to **Settings > Features > Presence > My Status**.
On VVX 1500 phones, navigate to **Menu > Features > Presence > My Status**.
- 2 From the **My Status** screen, select your desired status.

Automatically Update Your Buddy Status

You can enable your phone to automatically set your status to Away when your phone is idle for a certain length of time. After you touch the screen or press a key on your phone, your status changes to *Available* again.

To enable your phone to automatically change your status when you're away:

- 1 Navigate to **Settings > Basic > Preferences > Presence > Idle Timeout**.
On VVX 1500 phones, navigate to **Menu > Settings > Basic > Preferences > Presence > Idle Timeout**.
- 2 From the **Idle Timeout** screen, enable an **Office Hours** and **Off Hours** timeout, and enter the number of minutes your phone should be idle before your status changes to Away.

For steps on how to set your office hours, see the section [Change Your Office Hours](#).

Access, Send, and Broadcast Messages

You can send, broadcast, and access a variety of audio, verbal, video, and written messages on VVX phones. This section includes the following topics:

- [Access Voicemail and Video Messages](#)
- [Send Instant Messages](#)
- [Broadcasting Messages with Group Paging](#)
- [Broadcasting Messages with Push to Talk](#)



Note: Feature availability

Your phone may not support all of the features described in this section. Check with your system administrator to find out which features are available on your phone.

Access Voicemail and Video Messages

Voicemail is available on all Polycom VVX phones. However, only VVX 1500 phones support video messages. Contact your system administrator to find out if your phone supports video messages.



Note: Set or change your voicemail greeting

Contact your system administrator or service provider for information on setting or changing your voicemail greeting.

Your phone indicates when you have new voicemail and video messages in the following ways:

- The Message icon on the Home screen displays the number of new messages you have
- A Message icon with the number of messages is displayed in the status bar
- The Message icon is displayed next to the phone line on the Lines screen
- A red flashing Message Waiting Indicator, located at the top-right of your phone
- An audible alert

To access voicemail and video messages:

- 1 From the **Home** screen, navigate to **Messages > Message Center**.
On VVX 1500 phones, press the **Message** key and select **Message Center**.
- 2 If you have multiple lines on your phone, select the line that has the new message.
- 3 From the **Messages** screen, select **Connect** and follow the prompts to access your messages.



Note: Accessing voicemail remotely

Contact your system administrator or service provider for information on remotely accessing your voicemail.

Remove Message Alert

If you are not ready to listen to your messages when you receive new messages, you can temporarily remove the message alert.

To temporarily remove a message alert:

- » From the **Home** screen, navigate to **Messages > Message Center** and select **Clear**.
On VVX 1500 phones, press the **Message** key.
All message indicators are removed for about one to two hours.

Send Instant Messages

You can send and receive instant messages using your phone. Instant messaging is an optional feature. Contact your system administrator to find out whether instant messaging is enabled on your phone.

When you send a message, you can either select a message from a preset list of short messages, for example, “Call me” and “Can’t chat now”, or you can use the dial pad or onscreen keyboard to enter a custom message.

To send an instant message

- 1 From the **Home** screen, navigate to **Messages > InstantMessage**.
On VVX 1500 phones, press the **Message** key and select **Instant Message**.
The Instant Messages screen is displayed.
- 2 If you have multiple lines on your phone, select a line.
- 3 From the **Instant Messages** screen, select the **New** softkey.
- 4 Enter a contact’s phone number, URL, or IP address, and select **OK**.
The phone number, URL, or IP address you entered is displayed on the screen.
- 5 Do one of the following:

- Press **Select** to choose a pre-scripted message from the **Message Select** screen.
 - Select **Edit** to compose a custom message, and enter your message.
- 6 Select **Send**.

Read Instant Messages

Instant messages display in the order they are received with the first message received displaying first.

To read instant messages:

- 1 From the **Home** screen, navigate to **Messages > InstantMessage**.
On VVX 1500 phones, press the **Message** key and select **Instant Messages**.
- 2 If you have multiple lines on your phone, select a line.
The first message received is displayed.
- 3 Select the **Next** or **Previous** soft key to read additional messages, if available.

Reply to Instant Messages

After you read an instant message on your phone, you can send a reply to the message.

To reply to instant messages:

- 1 From the **Instant Messages** screen, select the **Reply** softkey.
- 2 Enter a message and select **Send**.

Delete Instant Messages

You can choose to delete older instant messages from your phone.

To delete instant messages:

- » Select a message and select the **Delete** soft key.

Broadcasting Messages with Group Paging

Group Paging enables you to make pages—one-way audio announcements—to contacts subscribed to a page group. Your administrator can enable your phone to operate in a broadcast mode called Group Paging mode. In this mode, you can broadcast one-way announcements to a specified group of phones, called a Paging Group.

Your system administrator can define up to 25 paging groups. Your system administrator can assign a label to each group to identify the phones in the group, such as All, HR Dept, Shipping Staff, or Executives.

Each group has one of the following priorities:

- *Normal* By default, broadcasts sent to groups 1 to 23 are considered Normal broadcasts. If two users begin a broadcast on the same group at the same time, the phone with the lower serial number continues to transmit while the other phone enters the receiving state. By default, all phones are configured to receive broadcasts sent to group 1.

- *Priority* By default, broadcasts sent to group 24 are considered Priority broadcasts. A Priority broadcast interrupts Normal broadcasts or active calls. All phones receive Priority broadcasts unless Do Not Disturb is enabled. Priority broadcasts play at the phone's current audio level.
- *Emergency* By default, broadcasts sent to group 25 are considered Emergency broadcasts. An Emergency broadcast interrupts Normal broadcasts, Priority broadcasts, and active calls and plays out at near maximum volume even if Do Not Disturb is enabled.

Sending and Receiving Pages

To send and receive pages, you need to subscribe to certain paging groups. By default, you are subscribed to paging groups 1, 24, and 25. This means that you can send and receive pages to paging groups 1, 24, and 25. Contact your system administrator to find out which paging group you are subscribed to.

Send Pages

When you send a group page, it is automatically sent to paging group 1, which is your default paging group.

You can change the default paging group to any group you want. To change the default paging group, see the section [Change the Default Paging Group](#). If you change your default paging group, you are automatically subscribed to the group you selected.

You cannot send a page while you are in an active call.

To send a page:

- 1 From the Lines screen, select the **Paging** soft key.
- 2 From the **Paging Groups** screen, select the paging group to send the page to.
- 3 To begin a page, select **Page**.
Just before the page starts, you'll hear an alert tone, and then the page begins.
- 4 Begin speaking.
- 5 To end the page, select **End Page**.

Receiving Pages

To receive a page sent to a particular paging group, you need to be subscribed to that group. To subscribe to a paging group, see the section [Update Paging Group Subscriptions](#).

How you receive a page depends on the priority of the page, whether you are in an active call, and whether your phone is set to receive a page during an active call. When you receive a page, the page is always played through the phone's speakerphone. You cannot play a page through your handset or headset.

You receive pages on the paging groups you are subscribed to as well as Group 24, Priority pages, and Group 25, Emergency pages. When you enable Do Not Disturb, you only receive Emergency pages. Non-emergency pages do not display or play on your phone.

Receiving Pages When You're Not in an Active Call

When you receive a page and you are not in an active call, the page immediately plays, regardless of the paging priority.

While a page plays, you can:

- Hold the page.
- End the page. This ends the page at your phone only.
- Place a new call.

Listen to Pages during Active Calls

How you handle a page when you are in an active call depends on the page priority and whether your phone is set up to receive a page when you are in an active call.

The following occurs when you receive a page during a call:

- When your phone is set up to receive Normal pages during active calls, the page immediately plays, and you hear audio from both the active call and the page.
- When your phone is not set up to receive Normal pages during active calls, the page is displayed as a Pending page.
- When the page is a Priority or Emergency page, the page immediately plays. You hear audio from the active call and the page.

To listen to a page during a call:

- » Do one of the following,
 - For pages that play automatically during a call, hold the call to hear only the page.
 - For Pending pages, select **Accept** or hold the call.

When you adjust the volume of a non-emergency page, your phone uses the adjusted volume for subsequent non-emergency pages. However, only your system administrator can change the volume of an Emergency page.

Changing Group Paging Settings

This section provides information on changing your default paging group, updating page group subscriptions, and enabling pages to play during active calls.

Change the Default Paging Group

When you press and hold Paging, your page is automatically sent to the default paging group 1. You can change the default paging group to any other group.

To change the default paging group:

- 1 Navigate to **Settings > Basic > Preferences > Paging/PTT Configuration > Group Paging**.
On VVX 1500 phones, navigate to **Menu > Settings > Basic > Preferences > Paging/PTT Configuration > Group Paging**.
- 2 From the **Group Paging Configuration** screen, select **Default Group**, and select a new paging group number.

When you press Paging, your phone sends pages using the new group.

Update Paging Group Subscriptions

By default, you are subscribed to Paging Groups 1, 24, and 25. This means that you can send pages to and receive pages sent from these groups. You can change which groups you are subscribed to. However, you cannot disable your subscriptions to Paging Groups 24 and 25.

To update your Paging Group subscriptions:

- 1 Navigate to **Settings > Basic > Preferences > Paging/PTT Configuration > Group Paging**.
On VVX 1500 phones, navigate to **Menu > Settings > Basic > Preferences > Paging/PTT Configuration > Group Paging**.
- 2 From the **Group Paging Configuration** screen, select **Group Subscriptions**.
- 3 From the **Group Subscriptions** screen, select the group you want to subscribe to, and select **Yes**.

Enable Pages to Play during Active Calls

The Accept While Busy setting determines what happens when you are in a call and receive a page. This setting is disabled by default, and when disabled, the incoming page is held in a Pending state, it does not disrupt the call, and you cannot hear the page.

When you enable the Accept While Busy setting, a page interrupts calls and you hear the audio of the call and the page.

To enable or disable pages to play during an active call:

- 1 Navigate to **Settings > Basic > Preferences > Paging/PTT Configuration > Group Paging**.
On VVX 1500 phones, navigate to **Menu > Settings > Basic > Preferences > Paging/PTT Configuration > Group Paging**.
- 2 From the **Group Paging Configuration** screen, scroll to **Accept While Busy**, and enable or disable the setting.

Broadcasting Messages with Push to Talk

The Push-to-Talk (PTT) feature enables you to transmit messages and listen to replies much like a walkie-talkie.

Your system administrator sets up the feature, defines up to 25 channels for PTT mode, and assigns a label to each channel that easily identifies the channel, such as All, HR Dept, Shipping Staff, or Executives.

Each group or channel has one of the following priorities:

- *Normal* By default, broadcasts sent to channels 1 to 23 are considered Normal broadcasts. If two users begin a broadcast on the same group/channel at the same time, the phone with the lower serial number continues to transmit while the other phone enters the receiving state. By default, all phones are configured to receive broadcasts sent to channel 1.
- *Priority* By default, broadcasts sent to channel 24 are considered Priority broadcasts. A Priority broadcast interrupts Normal broadcasts or active calls. All phones receive Priority broadcasts unless Do Not Disturb is enabled. Phones play Priority broadcasts at the phone's current audio level.
- *Emergency* By default, broadcasts sent to channel 25 are considered Emergency broadcasts. An Emergency broadcast interrupts Normal broadcasts, Priority broadcasts, and active calls and plays out at near maximum volume even if Do Not Disturb is enabled.

Sending and Receiving PTT Broadcasts



By default, you are subscribed to Channels 1, 24, and 25. This means that you can send and receive PTT broadcasts on Channels 1, 24, and 25.

When you end a PTT broadcast, the channel remains open and enters a 10-second waiting period. This waiting period gives people who received the broadcast a chance to respond. If no one responds within the waiting period, the channel closes.

Send PTT Broadcasts

You can choose a channel to broadcast on before you send a PTT broadcast, or you can hold the **Talk** soft key to immediately begin broadcasting on Channel 1, the default channel.

You can change your default channel to any other channel (see [Change the Default Channel](#)). When you change the default channel, you are automatically subscribed to the channel you selected.

While you send a broadcast, you can pick up the handset, or press the Speakerphone  or Headset  key, and continue speaking. You can also press the Mute key  to mute your audio so that the people receiving your broadcast do not hear anything. This behavior is similar to a phone call.

To send a PTT broadcast:

- 1 Select **Talk**.
- 2 From the **PTT Channels** screen, select a channel.
A list is displayed with the default channel, the most recent channel you sent a broadcast on, and other channels you can broadcast on.
- 3 Press and hold **Talk** to start the broadcast. Be sure to hold **Talk** throughout the entire broadcast.
A transmitting beep is played then the phone displays the channel information.
- 4 Begin speaking.
- 5 When you finish your broadcast, do one of the following:
 - Release **Talk**.
When you release Talk while sending the broadcast, the broadcast temporarily stops and enters a 10-second waiting period. During this period, the channel remains open to give others a chance to reply. At any time during the waiting period, you can resume your broadcast by pressing and holding Talk. If no one broadcasts during the waiting period, the channel closes and the broadcast ends.
 - Select **End PTT**.
After you select End PTT, you can immediately initiate another broadcast on another channel, even if the previous broadcast is in the waiting period.



Tip: Automatically sending a PTT broadcast

To automatically send a PTT broadcast on the default channel, press and hold **Talk**. After the transmitting beep, begin speaking.

Receiving PTT Broadcasts

To receive a broadcast sent on a particular channel, you need to be subscribed to that channel. To subscribe to a channel, see [Update Channel Subscriptions](#).

How you receive a PTT broadcast depends on the broadcast priority, whether you are in an active call, and whether your phone is set up to receive broadcasts during active calls.

When you enable Do Not Disturb on your phone, you receive only Emergency broadcasts. Non-emergency broadcasts do not display or play on your phone.

Receiving PTT Broadcasts When Not in an Active Call

When you receive a broadcast and you are not in an active call, the broadcast immediately plays, regardless of the broadcast priority.

When you adjust the volume of a non-emergency broadcast, your phone retains the adjusted volume for all subsequent non-emergency broadcasts. However, only system administrators can adjust the volume level of an Emergency broadcast.

Listen to PTT Broadcasts during Active Calls

How you handle a broadcast when you are in an active call depends on the broadcast priority and if your phone is set up to receive a broadcast when you are in an active call.

The following occurs when you receive a broadcast during an active call:

- When your phone is set up to receive Normal broadcasts during an active call, the broadcast immediately plays. You hear both the active call and the broadcast.
- When your phone is not set up to receive broadcasts during active calls, the broadcast is displayed as a Pending broadcast.
- When the broadcast is a Priority or Emergency broadcast, the broadcast plays immediately. You hear the active call and the broadcast.

To listen a broadcast during a call:

- » Do one of the following,
 - For broadcasts that play automatically during a call, hold the call to hear only the broadcast.
 - For Pending broadcasts, select **Accept** or hold the call.

Reply to PTT Broadcasts

When a broadcast ends, the broadcast enters a 10-second waiting period. During this period, the channel remains open to receive or send additional broadcasts.

To reply to a PTT Broadcast:

- 1 During the 10-second waiting period, press and hold **Talk**
- 2 Begin talking.
The broadcast is sent to all people listening on the channel.
- 3 When you finish talking, release **Talk**.

The broadcast enters another waiting period until someone broadcasts again. If no activity occurs within the waiting period, the channel closes and no more broadcasts can take place.

End PTT Broadcasts

After you end a broadcast, the channel remains open so others can respond.

To end PTT broadcasts:

- » Do one of the following:
 - Release **Talk**:
The broadcast enters a waiting period, and you cannot initiate another broadcast on another channel until the waiting period ends.
 - Select **End PTT**:
The broadcast ends, and you cannot resume the broadcast by pressing and holding Talk on the same channel. You can immediately initiate another broadcast on another channel.

Changing PTT Settings

This section provides information on the changing your default channel, updating channel subscriptions, and enabling broadcasts to play during active calls.

Change the Default Channel

When you press and hold **Talk**, your broadcast automatically transmits on the default channel 1. You can change the default channel to a different channel.

To change the default channel:

- 1 Navigate to **Settings > Basic > Preferences > Paging/PTT Configuration > PTT Push to Talk**.
On VVX 1500 phones, navigate to **Menu > Settings > Basic > Preferences > Paging/PTT Configuration > PTT Push to Talk**.
- 2 From the **PTT Channel Configuration** screen, select **Default Channel**, and select the number of the channel you want to use.

When you press Talk, your phone sends broadcasts using the new channel.

Update Channel Subscriptions

You can subscribe to any channel that has been enabled by your administrator and appears in your channels list. When you subscribe to a channel, you can send and receive PTT broadcasts on that channel.

To subscribe to additional PTT channels:

- 1 Navigate to **Settings > Basic > Preferences > Paging/PTT Configuration > PTT Push to Talk**.
On VVX 1500 phones, navigate to **Menu > Settings > Basic > Preferences > Paging/PTT Configuration > PTT Push to Talk**.
- 2 From the **PTT Channel Configuration** screen, select **Channel Subscriptions**.
- 3 From the **Channel Subscriptions** screen, select the channel you want to subscribe to, and select **Yes**.

Enable PTT Broadcasts to Play During Active Calls

The *Accept While Busy* setting determines what happens when you are in a call and receive a PTT broadcast. The default setting is disabled by default, and when disabled, your phone does not play broadcasts while you are in a call, but holds them in a Pending state instead. When you enable the *Accept While Busy* setting, a PTT broadcast interrupts active calls and you hear the audio of the call and the broadcast.

To enable PTT broadcasts during an active call:

- 1 Navigate to **Settings > Basic > Preferences > Paging/PTT Configuration > PTT Push to Talk**.
On VVX 1500 phones, navigate to **Menu > Settings > Basic > Preferences > Paging/PTT Configuration > PTT Push to Talk**.
- 2 From the **PTT Channel Configuration** screen, select **Accept While Busy**, and select **Enable**.

Use Applications on Your Phone

VVX phones can support optional applications configured by your system administrator. Ask your system administrator if your phone supports any of the applications discussed in this section, which includes the following topics:

- [Using the Calendar](#)
- [Navigating the Browsers](#)
- [Using the Launch Pad on VVX 1500 Phones](#)

Using the Calendar

When your VVX phone is configured to connect to Microsoft Exchange Server, you can view and join meetings scheduled in your Microsoft Outlook application from your phone.

This feature is not available for VVX 101 and 1500 phones. Check with your system administrator to find out if this feature is available on your phone.

Open the Calendar

You can access the calendar on your phone to view and join your meetings for the day.

To open the calendar:

- » Select Calendar from the Home screen or navigate to **Settings > Features > Calendar**.

The calendar displays your meetings for the day, which is Day view.





Troubleshooting: Why doesn't the calendar display?

If you select Calendar, and the Calendar does not display, it is possible your login credentials are incorrect or the Calendar is not connected. See the section [Application Issues](#) for more information.

Navigate Day View

In Day view, you can see your scheduled meetings for the day, and you can navigate to a previous or upcoming day.

To navigate Day view:

- » Do one of the following:
 - To view the previous day, select **Previous** or tap the Left-facing arrow .
 - To view an upcoming day, select **Next** or tap the Right-facing arrow .

- To view a meeting, use the arrow keys to select a meeting or tap the meeting.

Navigate to Other Views

From Day view, you can also access other calendar views: Month and Meeting view. Note that month view is not available on VVX 201 phones.

To display other calendar views from Day view:

- » Do one of the following:
 - Select **Month** or tap the Calendar icon  to access Month view.
 - Select a meeting to display Meeting view.



Navigate Month View

Month view displays all the days in the month, with a dot next to the days that have meetings. The current day is displayed in a darker color, and days you select display in grey.

From Month view, you can select a date to view meetings for that day, and you can also view meetings for previous and upcoming months.

Month view is not available on VVX 201 phones.

To navigate Month view:

- » Do one of the following:
 - To view the previous month, select **Previous** or tap the Left-facing arrow .
 - To view an upcoming month, select **Next** or tap the Right-facing arrow .
 - To view meetings, use the arrow keys to select a day or tap a day.

Display Meeting View

Meeting view displays the details for a chosen meeting. From Meeting view, you can view the meeting's start and end time, location, organizer, required attendees, and meeting description; view meeting numbers that you can call to join meetings; and join meetings.

To display Meeting view:

- » Do one of the following:
 - From **Day** view, select a meeting.
 - From **Month** view, select a date and select a meeting.

Return to Day View

Day view is the default Calendar view. You can return to Day view from Month or Meeting view.

To return to Day view:

- » Select **Exit** or tap the Exit soft key .

Use Meeting Reminders

By default, your phone displays a meeting reminder 15 minutes before a meeting starts. Every minute before the meeting starts, the phone emits an alert tone and updates the meeting timer. If a meeting starts and you have not joined the meeting, the reminder indicates that the meeting is overdue.

From the reminder, you can join a meeting, view meeting details, snooze the reminder to temporarily remove the reminder from the screen, and dismiss the reminder to permanently remove the reminder from the screen and stop all future reminders for the meeting. The following figure shows a meeting reminder.

Meeting reminder on VVX 400 phones

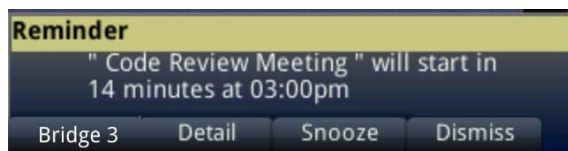

To use the meeting reminder:

- » Do one of the following:
 - Select the meeting number to join the meeting.
 - Select **Detail** to view information for the meeting.
 - Select **Snooze** to temporarily remove the meeting reminder from your screen for one minute.
 - Select **Dismiss** to permanently remove the reminder for this meeting.

Choose a Meeting Reminder Type

You can choose to have the following types of meeting reminders on your phone:

- *Silent* The meeting reminder is displayed on your phone and no alert tone plays.
- *Audible Once* An alert tone plays the first time a meeting reminder is displayed, but does not play for additional reminders for the meeting.
- *Audible Always* An alert tone plays each time a meeting reminder is displayed on your phone.

To choose the meeting reminder type:

- 1 Navigate to **Settings > Basic > Preferences > Calendar Settings > Reminder Settings**.
- 2 From the **Reminder Settings** screen, select **Reminder Type**, and choose a type.

Choose an Alert Tone

You can also choose the alert tone that plays for meeting reminders.

To choose an alert tone:

- 1 Navigate to **Settings > Basic > Preferences > Calendar Settings**.
- 2 From the **Calendar Settings** screen, select **Alert Tone**.
- 3 Choose an alert tone and tap **Play** to hear the tone.

Disable Meeting Reminders

Meeting reminders are enabled on your phone by default. When enabled, your phone displays reminders for all meetings. You can choose to disable meeting reminders so they do not display on your phone for any meetings.

To disable meeting reminders:

- 1 Navigate to **Settings > Basic > Preferences > Calendar Settings > Reminder Settings**.
- 2 From the **Reminder Settings** screen, select **Reminder > Disable**.



Troubleshooting: Why don't my meeting reminders display?

If you have enabled meeting reminders, but your phone is not displaying them, make sure that your login credentials are correct.

Joining Calendar Meetings

You can join any meeting from the calendar or from meeting reminders using the meeting number.

Join Meetings from the Calendar

You can join meetings from the Calendar from Meeting view.

To join a meeting from Meeting view:

- 1 From **Day** view, select the meeting.
- 2 In **Meeting** view, select a meeting number.

Join a Meeting from a Meeting Reminder

You can join a meeting from the meeting reminder when it displays before a meeting.

To join a meeting from a meeting reminder:

- » Select the meeting number that is displayed in the reminder.

Join a Meeting with an Alternate Number

If the meeting organizer has provided alternate numbers you can use to join the meeting, you can choose to view and use alternate numbers to join the meeting.

To join a meeting using an alternate meeting number:

- » Do one of the following:
 - From **Meeting** view, select **More Actions** and choose a number.
 - From the meeting reminder, select **Detail > More Actions**, and select a number.

Navigating the Browsers

VVX phones support the following types of browsers:

- *Idle Browser* Displays non-interactive web content (not supported on VVX 1500 phones).

- *Web Browser* Enables you to search and navigate web pages (not supported on VVX 101 and 201 phones).

Ask your system administrator if the Idle and Web browsers are available on your phone.

View the Idle Browser

The Idle Browser shows non-interactive web content on the idle screen that displays when your phone is idle and doesn't have any calls in progress. Your system administrator determines what displays on the Idle Browser for your phone.

When your phone is idle, you can view an Idle Browser when you switch between the Home and Lines screens. To see the Idle Browser, you need to enable the screen saver (see the section [Enabling Screen Savers](#)).

To view the Idle Browser:

- » When your phone is idle, press .

Use the Web Browser

The Web Browser is an interactive browser that you can use to search the Internet and view web pages. From the Web Browser, you can select hyperlinks to view more web pages, enter information into text boxes, and scroll through web pages. There are scrolling indicators on the screen that indicate your position on the web page.

When you open the Web Browser, a toolbar with navigation and editing soft keys is displayed for three seconds along the bottom of the screen, as shown next. You can use the navigation and editing soft keys to navigate between web pages and enter information into text boxes in the Web Browser.











To view the Web Browser:

- » From the **Home** screen, select **Applications**. On VVX 1500 phone, press the **Applications** key.

Browser Navigation Soft Keys

The navigation soft keys in the Web Browser enable you to view previous web pages, refresh the current page, return to the browser's Home page, or return to your phone's Home screen. The following table lists the navigation soft keys that display in the Web Browser.

Navigating the Web Browser

Icon	Action
	Returns to the previous web page.
	Refreshes the current web page.
	Stops refreshing.
	Returns to the browser's home page.
	Displays the toolbar permanently so it does not hide every three seconds. When the toolbar is permanently enabled, the icon changes to  .
	Enables the toolbar to hide every three seconds. To display a hidden toolbar, you have to press the touchscreen until the toolbar displays. (VVX 500, 600, and 1500 phones)
	Returns to the phone's Home screen.

Enter Information into the Browser



The editing icons in the Web Browser enable you to enter information in text boxes.

To display the editing icons:

- » Select a text box in the Web Browser.

The following table lists the editing icons that display in the Web Browser.

Editing and Entering Text in the Web Browser

Icon	Action
	Selects lowercase, uppercase, or numerical mode, or a special character encoding.
	Displays an onscreen keyboard (VVX 500, 600, and 1500 phones).
	Hides the editing icons and display the navigation icons.

Using the Launch Pad on VVX 1500 Phones

The Launch Pad on VVX 1500 phones is an optional feature that enables you to access local or web applications, directories, and information feeds from your phone. Ask your system administrator if the Launch Pad is enabled on your phone.

When the Launch Pad is enabled on your phone, your system administrator can customize the applications you see. By default, the Launch Pad displays the following applications:

- *Picture Frame* Displays your pictures stored on a USB flash drive.
Using the Picture Frame application, you can display your pictures as thumbnails, one-by-one, like a slide show, or display just one picture. You can also use the Picture Frame application to set one of your pictures as the background image on your phone. For information on how to use Picture Frame, see [Use Your Phone as a Digital Picture Frame](#) and [Adding Personal Photos as Your Background](#).
- *My Info Portal* Gives you access to a variety of information feeds, such as sports, news, weather, stock, and traffic. See the section [Enable My Info Portal](#) to enable this feature.

Your system administrator can also set up your phone so that you can view feeds from the idle screen, as well as from the Launch Pad. When you view feeds from the Launch Pad or from the idle screen, your phone is considered idle and a screen saver is displayed, if you have set up a screen saver (see [Enabling Screen Savers](#)).

Access the Launch Pad

You can access the Launch Pad from the Applications menu.

To access the Launch Pad:

- » Press the **Applications** key.
The Launch Pad's main window is displayed.

Open Applications

The Picture Frame and My Info Portal applications are default applications available in the Launch Pad. Your administrator can enable additional applications for your phone that can also be available in the Launch Pad.

To open an application from the Launch Pad:

- » Do one of the following:
 - Select the **Picture Frame** icon.
 - Select the **My Info Portal** icon, and select the feed you want to view.
If you haven't enabled the My Info Portal application yet, you have to set up an account before you can access the application. See [Enable My Info Portal](#).
 - Select an additional application to launch.

For information on using custom applications, contact your system administrator.

Navigate the Launch Pad

When you are using the Launch Pad application, a group of soft keys display to help you navigate the Launch Pad.

To navigate the Launch Pad:

- » Do one of the following:
 - Tap **Home** to display the Launch Pad's main window, with all the Launch Pad applications.
 - Tap **Refresh** to refresh the Launch Pad window so you can access an updated application.
 - Tap **Back** to launch the previous application you viewed.
 - Tap **Exit** to return to the Home screen.

Display the Launch Pad's Main Screen

When you exit a Launch Pad application without returning to the Launch Pad's main window first, or when a Launch Pad window times out, the next time you access the Launch Pad, the last window you viewed is displayed instead of the Launch Pad's main window.

To display the Launch Pad's main screen:

- » Select the **Home** or **LaunchPad** soft key.

Enable My Info Portal

Before you can access the applications within My Info Portal, you have to sign up for a My Info Portal account.



Note: Your account information is secure

Information you provide when you set up an account is securely transmitted using the HTTPS security protocol.

To enable My Info Portal:

- 1 Press the **Applications** key.
The Launch Pad's main window is displayed.
- 2 Select the **My Info Portal** icon.
- 3 From the **My Info Portal – Welcome** screen, select **Sign Up**, and enter your account information.
- 4 After you enter your account information, select **Sign Up**.

You can now access the My Info Portal applications, and view the information feeds.

If your system administrator has set up My Info Portal to display on your idle screen, you can also see information feeds from the idle screen.

Customize Your Phone

This section explains how to customize your phone so that it is unique to you. Basic customizations include changing the time and date format and updating the screen brightness. You can also set up a screen saver or use your phone as a digital picture frame.

This section includes the following topics:

- [Set the Language](#)
- [Set the Time and Date Display](#)
- [Setting the Backlight Intensity and Timeout](#)
- [Select a Background Picture](#)
- [Enable Transparent Line Keys](#)
- [Enabling Screen Savers](#)
- [Use Your Phone as a Digital Picture Frame](#)
- [Using Power-Saving Mode](#)
- [Changing Audio Settings](#)

Set the Language

Your phone supports several languages that you can choose to display. Check with your system administrator to find out which languages are supported on your phone.

To change the language:

- 1 Navigate to **Settings > Basic > Preferences > Language**.
On VVX 1500 phones, navigate to **Menu > Settings > Basic > Preferences > Language**.
- 2 From the **Language** screen, select a language.
The language on your phone updates automatically.

Set the Time and Date Display

The time and date display in the status bar. When your phone cannot obtain a time and date, the time and date display flashes. If this happens, or if the time and date are incorrect, contact your system administrator.

The following figure shows the default format for the time and date.



You can customize the time and date by choosing between a variety of time and date formats, including options to display the day, month, or year.

To update the time and date display:

- 1 Navigate to **Settings > Basic > Preferences > Time & Date**.
On VVX 1500 phones, navigate to **Menu > Settings > Basic > Preferences > Time & Date**.
- 2 From the **Time & Date** screen, do one of the following:
 - Select **Clock Date** to change the date format.
 - Select **Clock Time** to change the time format.
 - Select **Clock Order** to change the order of the time and date display (not available on VVX 101 and 201 phones).
- 3 From the **Clock Date**, **Clock Time**, or **Clock Order** screen, select the format you want.

Disable the Time and Date Display

You can turn off the time and date display so that they do not display at all.

To disable the time and date display:

- 1 Navigate to **Settings > Basic > Preferences > Time & Date**.
On VVX 1500 phones, navigate to **Menu > Settings > Basic > Preferences > Time & Date**.
- 2 From the **Time & Date** screen, select **Disable** to turn off the time and date display.

Setting the Backlight Intensity and Timeout

Your phone's backlight has the following components:

- *Backlight Intensity* The brightness of the screen during phone activity and inactivity.
- *Backlight Timeout* The number of seconds the phone is inactive before the backlight dims to its Backlight Idle intensity. The backlight timeout period begins after your last key press or the last phone event, such as an incoming call.

Backlight Intensity includes the following settings you can choose from:

- *Backlight On* The brightness of the screen when there is phone activity.
- *Backlight Idle* The brightness of the screen when there is no phone activity.
- *Maximum Intensity* The brightness scale that applies to both Backlight On and Backlight Idle intensities.

This feature is not available on VVX 101 phones. Check with your system administrator to find out if this feature is available on your phone.

Change the Backlight Intensity

You can change the Backlight On intensity and the Backlight Idle intensity separately, and you can choose a high, medium, or low intensity, or turn off the backlight entirely. When you change the Maximum Intensity,

you modify the entire backlight intensity scale. For example, if you decrease the Maximum Intensity, the low, medium, and high levels for both Backlight On and Backlight Idle intensities decrease.

To change the backlight intensity:

- 1 Navigate to **Settings > Basic > Backlight Intensity**.
On VVX 1500 phones, navigate to **Menu > Settings > Basic > Backlight Intensity**.
- 2 From the **Backlight Intensity** screen, select **Backlight On Intensity**.
- 3 From the **Backlight On Intensity** screen, select the intensity you want, and select **Back**. The default is High.
- 4 From the **Backlight Intensity** screen, select **Backlight Idle Intensity**.
- 5 From the **Backlight Idle Intensity** screen, select the intensity you want, and select **Back**. The default is Low.
- 6 From the **Backlight Intensity** screen, select **Maximum Intensity**.
- 7 From the **Maximum Intensity** screen, select **Up** or **Down**, or drag your finger along the slider, to increase or decrease the maximum intensity.

Change the Backlight Timeout

The backlight automatically turns on with any phone activity. By setting the Backlight Timeout, you can determine how long the phone should be idle before the backlight dims to its Backlight Idle intensity. By default, the backlight dims after the phone is idle for 40 seconds.

To change the Backlight Timeout:

- 1 Navigate to **Settings > Basic > Backlight Timeout**.
On VVX 1500 phones, navigate to **Menu > Settings > Basic > Backlight Timeout**.
- 2 From the **Backlight Timeout** screen, select the number of seconds the phone is idle before the backlight dims. The default is 40 seconds.

Select a Background Picture

By default, your screen displays a blue background that is named Default. You can change the background picture that is displayed on your phone to any image set up by your system administrator. If no background images are set up, only the Default is available.

You can also use a picture of your own as the background image for your phone. For more information, see [Adding Personal Photos as Your Background](#).

This feature is not available on VVX 101 and 201 phones. Check with your system administrator to find out if this feature is available on your phone.

To change the background picture:

- 1 Navigate to **Settings > Basic > Preferences > Background**.
On VVX 1500 phones, navigate to **Menu > Settings > Basic > Preferences > Background**.
The Background screen is displayed.
Depending how your system is set up, you might have to navigate to **Settings > Basic > Preferences > Background > Select Background**. The **Select Background** screen is displayed instead.
- 2 Select a background image, if available.

Adding Personal Photos as Your Background

You can upload a personal photo to use as your background using the Web Configuration Utility or using a USB flash drive on VVX 500, 600, and 1500 phones. When you set one of your pictures as the background picture, the picture is displayed as *Local File* in the Backgrounds list.



Note: Restrictions for background images

Keep in mind the following when you use a personal photo as the background image:

- Progressive or multiscan JPEG images are not supported.
- The phone screen sizes vary by phone:
 - ▲ VVX 300 and 400 phone screens are 220 x 108 pixels
 - ▲ VVX 500 phone screens are 320 x 240 pixels
 - ▲ VVX 600 phone screens are 480 x 272 pixels.
 - ▲ VVX 1500 phone screens are 800x480 pixels.
- Smaller images are centered and surrounded with black space.
- Larger images are scaled proportionally to fit the screen.
- Horizontal or vertical black bars are added to preserve the original aspect ratio.

Using the Web Configuration Utility

In the Web Configuration Utility, you can upload pictures to your phone to save as your background.

Find Your Phone's IP Address

To access the Web Configuration Utility, you need your phone's IP address.

To find your phone's IP address:

- » Navigate to **Settings > Status > Platform > Phone**.
On VVX 1500 phones, navigate to **Menu > Status > Platform > Phone**.



Note: Accessing the Web Configuration Utility Disabled by Default

Access to the Web Configuration Utility may be disabled by default as a security precaution. Contact your system administrator for help enabling the Web Configuration Utility.

Add a Background Using the Web Configuration Utility

You can add one or multiple images for your phone background using the Web Configuration Utility.

To add your own picture using the Web Configuration Utility:

- 1 Enter your phone's IP address into the web browser on your computer.
- 2 Select **User**, and enter **123** for the Password.
- 3 From the menu bar, select **Preferences > Background**.
- 4 Click **+ Add a new background image**.
- 5 Click **Select a file from PC/Desktop**, and click **Choose File for Phone Image**.
- 6 Choose your picture file, and click **Open**.
- 7 Click **Save**.



The file is added to the list of possible backgrounds.

- 8 On your phone, navigate to **Settings > Basic > Preferences > Background**.
On VVX 1500 phones, navigate to **Menu > Settings > Basic > Preferences > Background**.
- 9 Select your background image.
The image is displayed as your background.

Use a USB Flash Drive

Before you can set a picture on your USB flash drive as the background picture, make sure the picture is on a USB flash drive and is not in a folder on the drive.

To use a picture on your USB flash drive as the background picture:

- 1 Attach a USB flash drive to the USB port on your phone.
- 2 Navigate to **Settings > Features > Removable Storage Media > Picture Frame**.
On VVX 1500 phones, navigate to **Menu > Features > Removable Storage**.
Your pictures display, one-by-one.
- 3 Tap the arrow icons   to find your picture, and tap the Background icon .

The picture you selected is displayed on the Home and Linescreens.



Troubleshooting: Why is my USB flash drive not displaying on my phone?

If your phone does not detect the USB flash drive when you attach it to your phone, the USB port on your phone may be disabled. Contact your system administrator and view the section [USB Port Issues](#) for more information.



Troubleshooting: Why aren't the pictures on my flash drive displaying on the phone?

If your pictures on the flash drive are in a subfolder and not in the root directory, the phone displays a message stating that there are no available photos. Make sure the picture you want to display on your phone is not in a subfolder on the flash drive.

Reset Your Background

You can reset your background to display the default image.

To reset your background image to the default:

- 1 Navigate to **Settings > Basic > Preferences > Background**.
On VVX 1500 phones, navigate to **Menu > Settings > Basic > Preferences > Background**.
- 2 From the **Background** screen, select **Default**.

Enable Transparent Line Keys

By default, your phone displays line keys with a blue background. If you have a background picture set on your VVX phone, the background is partially or fully covered depending on the amount of line keys you have. On VVX 500 and 600 phones, you can change line keys to have a transparent background that enables you to fully see the background you set for your phone.

To enable transparent line keys:

- 1 Navigate to **Settings > Basic > Preferences > Idle Screen Settings**.
On VVX 1500 phones, navigate to **Menu > Settings > Basic > Preferences > Idle Screen Settings**.
- 2 On the **Idle Screen Settings** screen, select **Transparent Lines**, and select **Enabled**.

The line keys are displayed without a background, as shown next.



Enabling Screen Savers

Another way to personalize your phone is to enable a screen saver that can either show default pictures stored on your phone, the idle browser, or pictures stored on a USB flash drive. Ask your system administrator if this feature is available on your phone.

This section includes the following topics:

- [Enable Screen Savers](#)
- [Use Personal Photos as Screen Savers](#)
- [Disable Screen Savers](#)

Enable Screen Savers

The screen saver automatically starts each time your phone is idle for a certain amount of time. When you enable the screen saver, you can choose to have your phone either display default photos stored on the phone, or the idle browser (see [View the Idle Browser](#)).

To enable a screen saver:

- 1 Navigate to **Settings > Basic > Preferences > Screen Saver**.
On VVX 1500 phones, navigate to **Menu > Settings > Basic > Preferences > Screen Saver**.
- 2 From the **Screen Saver** screen, select **Screen Saver** and select **Enabled**.
- 3 Select **Wait Time** and enter the number of minutes the phone can wait after no activity before displaying the screen saver.
You can enter any time between one and 9999 minutes. The default time is 15 minutes.
- 4 Select **Type** and select either **Default** or **Idle Browser**.
- 5 Press **Save**.

You can stop the screen saver at any time by pressing any key or touching the screen. When your phone is idle again for a specified period of time, the screen saver starts again.

Use Personal Photos as Screen Savers

On VVX 500, 600, and 1500 phones, you can enable your phone to display your personal photos as a screen saver. To set up a screen saver of your pictures, you need to set up certain screen saver settings, place your pictures on a USB flash drive, and attach the USB flash drive to the phone. See the section [View Your Phone Keys and Hardware](#) for the location of the USB port on your phone.



Web Info: Supported USB flash drives

For a list of supported USB flash drives, see [Technical Bulletin 38084: Supported USB Devices for Polycom Phones](#).

The pictures you use must have the following file type and size properties:

- File type: BMP, JPEG, or PNG
- Maximum size: 9999 x 9999 pixels

The phone can only display the photos as your screen saver when the USB flash drive is attached to the phone.

To set up a screen saver of your pictures:

- 1 Place one or more pictures on a USB flash drive, either in the root directory or in a folder.
- 2 Attach the USB flash drive to your phone.
The USB icon  is displayed on the status bar.
- 3 Navigate to **Settings > Basic > Preferences > Picture Frame**.
On VVX 1500 phones, navigate to **Menu > Settings > Basic > Preferences > Picture Frame**.
- 4 From the **Picture Frame** screen, select **Folder**, and enter the name of the folder you placed your images in on the USB flash drive.
If you did not place the pictures in a folder, but placed them in the root directory instead, do not enter a folder name.
- 5 Select **Time Per Image**, and enter the number of seconds you want each picture to display.
You can enter a minimum of 3 seconds and a maximum of 300 seconds. The default is 5 seconds.

6 Select **Save**.

If the message “No pictures found” displays after you select **Save**, there are no pictures in the folder you specified or in the root directory. Go back and make sure the information you entered is correct.

7 Navigate to **Settings > Basic > Preferences > Screen Saver**.

8 From the **Screen Saver** screen, select **Screen Saver**, and select **Enabled**.

9 Select **Wait Time**, and enter the number of minutes the phone should wait, after no activity, before displaying the screen saver.

You can enter any time between one minute and of 9999 minutes. The default is 15minutes.

10 Select **Save**.

Your phone displays the screen saver after the number of minutes you specified in the Wait Time field.



Troubleshooting: Why is my USB flash drive not displaying on my phone?

If your phone does not detect the USB flash drive when you attach it to your phone, the USB port on your phone may be disabled. Contact your system administrator and view the section [USB Port Issues](#) for more information.



Tip: Using your phone as a digital pictureframe

You can set up your phone to use a single picture to display or have all pictures display in slide-show style. This is an alternative to setting up a screen saver, and it automatically starts each time your phone is idle a certain amount of time. For more information, see the section [Use Your Phone as a Digital Picture Frame](#).

Disable Screen Savers

You can stop a screen saver at any time by touching the screen. After your phone is idle for the specified period of time, the screen saver starts again.

You can disable a screen saver—prevent it from starting, even if your phone has been idle for the specified period of time—by doing the following:

- Removing the USB flash drive. The screen saver does not display until you attach the USB flash drive again, and your phone is idle for the period of time you specified.
- Disabling the Screen Saver setting. When you disable the setting, the screen saver does not display, even though the USB flash drive is still attached.

To disable the Screen Saver setting:

1 Navigate to **Settings > Basic > Preferences > Screen Saver**.

On VVX 1500 phones, navigate to **Menu > Settings > Basic > Preferences > Picture Frame**.

2 From the **Screen Saver** screen, select **Screen Saver**, and select **Disabled**.

3 Select **Save**.

Use Your Phone as a Digital Picture Frame

On VVX 500, 600, and 1500 phones, you can use the Picture Frame feature to view pictures stored on your USB flash drive at any time, without setting up a screen saver. You can display your pictures as thumbnails, one-by-one like a slide show, or display just one picture.

Before you can display your pictures, confirm that your pictures are on the USB flash drive, and the USB flash drive is attached to your phone.



Troubleshooting: Why is my USB flash drive not displaying on my phone?

If your phone does not detect the USB flash drive when you attach it to your phone, the USB port on your phone may be disabled. Contact your system administrator and view the section [USB Port Issues](#) for more information.

To display the pictures on your USB flash drive:

- » Select **Settings > Features > Removable Storage Media > Picture Frame**.

On VVX 1500 phones, select **Menu > Features > Removable Storage Media > Picture Frame**.





Your pictures display one-by-one, like a slide show, and six icons display beneath your pictures, as shown next.



Performing Tasks in the Picture Frame

Use the icons in the following table to perform actions in the Picture Frame.

Selecting Icons to Display Your Pictures

Icons	Action
	View thumbnails of your pictures.
	View the previous picture.
	View the next picture.
	Pause and display the current picture only.

Selecting Icons to Display Your Pictures



Starts the display of pictures one-by-one again.



Stop displaying the pictures. The pictures do not display again until you access the Picture Frame feature (unless you have a screen saver enabled).



Set the picture that currently displays as the background picture for your phone.

Using Power-Saving Mode

By default, your phone is set up with a power-saving mode that turns off the screen to conserve energy. Your phone enters power-saving mode after it has been idle for a certain period of time. You can configure the period of time that the phone is idle before the screen turns off. You can configure different idle timeouts for office hours and off hours, such as evenings and weekends.

During off hours, the message “Off Hours Mode” scrolls on the status bar. Your phone exits power-saving mode if a phone event occurs—for example, if the phone has an incoming call or message, or you press a key or tap the screen. If a screen saver is enabled on your phone, power-saving mode still occurs.

You can update the following power-saving settings:

- *Office Hours* When you start work and how long you’re in the office each day (see [Change Your Office Hours](#)).
- *Timeouts* The period of time the phone should be idle before the screen turns off (see [Change Timeouts](#)).

Change Your Office Hours

When you update your office hours, you specify when you start and how long you work each day. After your work hours, the phone is idle and goes into power-saving mode.

To change your office hours:

- 1 Navigate to **Settings > Basic > Power Saving > Office Hours > Start Hour**.
On VVX 1500 phones, navigate to **Menu > Settings > Basic > Power Saving > Office Hours > Start Hour**.
- 2 From the **Start Hour** screen, select a day of the week.
- 3 Enter a start time using the 24-hour clock. You can enter a start time from 0 to 23.
- 4 Select **Save**.
- 5 From the **Office Hours** screen, select **Duration**.
- 6 From the **Duration** screen, select a day of the week.
- 7 Enter a duration of 0 to 12 hours per day.
- 8 Select **Save**.

Change Timeouts

You can update the period of time the phone is idle before the screen turns off. You can specify different timeouts for office hours (Office Hours Idle Timeout) and non-office hours (Off Hours Idle Timeout). By default, the Office Hours Idle Timeout is much longer than the Off Hours Idle Timeout.

You can also specify a separate timeout period that applies after you press a key or tap the screen. This is called the User Input Idle Timeout. You can choose to set a higher User Input Idle Timeout than the Office Hours and Off Hours Idle Timeouts so that when you're actively using the phone, power-saving mode doesn't initiate as often.



Tip: Determining which idle timeout applies

If you press a key or tap the screen, the idle timeout period that applies (User Input Idle Timeout or Office Hours/Off Hours Idle Timeout) is the timeout with the highest value.

To change timeouts:

- 1 Navigate to **Settings > Basic > Power Saving > Timeouts**.
On VVX 1500 phones, navigate to **Menu > Settings > Basic > Power Saving > Timeouts**.
- 2 Select **Office Hours Idle Timeout**, and enter the number of minutes the phone should wait, during office hours, before starting power-saving mode. Enter a number between 1 minute and 600 minutes. The default is 10 minutes.
- 3 Select **Off Hours Idle Timeout**, and enter the number of minutes the phone should wait, during off-hours, before starting power-saving mode. Enter a number between 1 minute and 10 minutes. The default is 1 minute.
- 4 Select **User Input Idle Timeout**, and enter the number of minutes the phone should wait after a key press or screen select before starting power-saving mode. Enter a number between 1 minute and 10 minutes. The default is 10 minutes.
- 5 Select **Save**.

Changing Audio Settings

You can change the following audio settings for your phone:

- [Change Incoming Call Notifications](#)
- [Set a Ringtone for Incoming Calls](#)
- [Set a Ringtone for Individual Contacts](#)
- [Change the Volume](#)

Change Incoming Call Notifications

You can choose whether you hear sound effects—all phone sounds except call audio—from the handset, headset, speaker, or the active audio device you set. For example, you can configure your phone to ring on your headset instead of the speaker. By default, you hear all sound effects from the speaker.

To change your incoming call notifications:

- 1 Navigate to **Settings > Basic > Preferences > Audible Ringer**.
On VVX 1500 phones, navigate to **Menu > Settings > Basic > Preferences > Audible Ringer**.
- 2 From the **Audible Ringer** screen, select a location to hear sound effects:

Set a Ringtone for Incoming Calls

A simple way to personalize your phone is to change your phone's ringtone. You can pick unique ringtones for the different lines on your phone. The default ringtone is Low Trill.



To select an incoming call ringtone for your phone or a line:

- 1 Navigate to **Settings > Basic > Ring Type**.
On VVX 1500 phones, navigate to **Menu > Settings > Basic > Ring Type**.
- 2 When there are multiple lines on your phone, select a line.
- 3 From the **Ring Type** screen, select a ringtone.
- 4 Select **Play** or tap the Play icon  to hear the ringtone.

Set a Ringtone for Individual Contacts

You can select unique ringtones for various contacts in your directory. This helps you quickly identify callers as your phone rings.

To select a ringtone for a contact:

- 1 From your **Contact Directory**, select a contact.
- 2 From the **Contact Information** screen, select **Edit** or tap the Edit icon .
- 3 From the **Edit Contact** screen, select **Ring Type** and select a ringtone.
- 4 Select **Play** or tap the Play icon  to hear the ringtone.
- 5 From the **Edit Contact** screen, select **Save**.

Change the Volume

You can increase the volume of your ringtone and the audio during a call.

To change the volume of the ringtone or audio during calls:

- » Press one of the Volume keys  to increase or decrease the audio.

Use Accessibility Features on Your Phone

This section provides information for the following accessibility features available on VVX business media phones:

- [Features for Hearing-Impaired Users](#)
- [Features for Vision-Impaired and Blind Users](#)
- [Features for Mobility-Impaired Users](#)

Features for Hearing-Impaired Users

The following table lists the accessibility features on VVX business media phones for hearing-impaired users.

Accessibility Features on VVX Business Media Phones for Hearing-Impaired Users

Accessibility Feature	Description
Visual Message Waiting Indicator (MWI)	An indicator light on the phone indicates that new messages are waiting. Icons on the phone screen also indicate that the phone has new messages.
Adjustable ring tone and volume	You can choose from a variety of ring tones for your phone. You can also change the volume of the ringer to suit your needs, and choose different ring tones for contacts (see Changing Audio Settings).
Adjustable call volume	If you're in a call, you can raise or lower the volume of the voice on the far end and of other phone sounds you hear (see Change the Volume).
Visual notifications	Indicators on the phone screen (such as flashing bars or icons) let you know when calls are incoming or outgoing, or if a call is active or held. Indicators can also indicate phone status and if certain features are activated (see Understanding Phone Icons and Status Indicators).
Visual ringing	Certain VVX models have visual ringing that enables the screen to flash bright orange for incoming calls (contact your system administrator).

Accessibility Features on VVX Business Media Phones for Hearing-Impaired Users

Electronic hookswitch support	If you use a headset that supports electronic hookswitch (EHS), you can use the controls on your headset to answer and end calls. In addition, you may be able to mute calls and control volume from your headset (see Enable Electronic Hookswitch).
Headset Memory Mode	If you use a headset, you can set up your phone so that all calls use your headset (see Use Your Headset for All Calls).
Hearing Aid Compatible (HAC) handsets	All VVX handsets are Hearing Aid Compatible (HAC) and have telecoils that magnetically couple to most forms of wearable hearing aids per FCC section 508 (compliant to ADA Section 508 Recommendations: Subpart B 1194.23).
TTY support	VVX phones support commercial TTY devices such as Ultratec Superprint. In addition, VVX phones provide acoustic coupled TTY support.

Features for Vision-Impaired and Blind Users

The following table lists the accessibility features on VVX business media phones for visually-impaired and blind users.

Accessibility Features on VVX Business Media Phones for Vision-Impaired and Blind Users

Accessibility Feature	Description
Adjustable backlight settings	You can change the brightness of the screen by adjusting backlight intensity settings (see Setting the Backlight Intensity and Timeout).
Tactile “5” key with raised bumps	The “5” key has two bumps that let you easily discern the position of other keys on the keypad.
Large keys	Large keys on the phone console enable you to easily access phone features and functions.
Physical line keys	VVX 300 and 400 phones have physical line keys that you can press to answer and end calls.
Variety of feature keys that you can press	Many features on VVX phones are accessible by pressing feature keys on the phone console.
Tactile-discernible number, feature, and navigation keys	Keys on the phone are tactile-discernible by size and shape.
Illuminated feature keys	Many feature keys are illuminated when activated, so you’re easily alerted when a feature is enabled.

Features for Mobility-Impaired Users

The following table lists the accessibility features on VVX business media phones for mobility-impaired users.

Accessibility Features on VVX Business Media Phones for Mobility-Impaired Users

Accessibility Feature	Description
Auto-answer feature	VVX phones can auto-answer calls, so you don't have to lift a handset, push a button, or select a key to answer a call (see Answer Calls Automatically).
Dedicated headset jack that enables the auto-answer function	
Touchscreen	VVX 500, 600, and 1500 phones have large touchscreens that you can select, swipe, and press to perform phone functions and activate features.
Large keys	VVX phones have large keys that are well-spaced on the phone console.
Built-in speakerphone	A built-in speakerphone allows you to use the phone without having to use a handset or headset.
Adjustable phone stand	VVX phones have stands that you can adjust to various angles so your phone sits at a comfortable angle on your desktop (see your phone's <i>Quick Start Guide</i> on Polycom Voice Support web page).
Polycom Desktop Connector application	

If you use a headset (see [Us](#)

You can u
navigate
[Connecto](#)

Extend Your Phone's Capabilities with Accessories

This section includes accessories and applications that you can use to extend your phone's capabilities. The following topics are included in this section:

- [Using a Headset with Your Phone](#)
- [Using the Polycom Desktop Connector](#)
- [Connecting a Netgear Wi-Fi Adapter to Your Phone](#)
- [Connecting Polycom VVX Expansion Modules to Your Phone](#)



Note: Feature availability

Your phone may not support all of the features described in this section. Check with your system administrator to find out which features are available on your phone.

Using a Headset with Your Phone

You can connect an analog or USB headset to your VVX phone and use the headset to place and answer calls, handle all calls using a headset, and use electronic hookswitch (EHS). You can also pair and connect a Bluetooth headset with your VVX 600 phone. See [Feature Profile 37477: Using Headsets with Polycom Phones](#) for a list of compatible headsets.

This section includes the following topics on using headsets:

- [Connecting a Headset](#)
- [Use Your Headset for All Calls](#)
- [Using Electronic Hookswitch](#)
- [Disconnect Your Headset](#)
- [Using Bluetooth Headsets with Your VVX 600 Phone](#)



Note: Features available on your headset

For information on your headset's features, as well as how to sync your headset with your phone, see your headset's documentation.

Connecting a Headset

For setup information on how to connect a headset to your phone, see the [Quick Start Guide](#) for your phone on the [Business Media Phones Support](#) page.

Your phone does the following when connected to analog and USB headsets:

- When an analog headset is connected and in use, the headset key glows green. Note that the headset key does not glow on VVX 101 and 201 phones.
- When a USB headset is connected and in use, the headset key glows blue (For VVX 1500 phones, the headset key glows green).
- When both an analog and USB headset are connected, the USB headset is used automatically for all calls.
- When two USB headsets are connected, the headset you connected first is used automatically for all calls.

After you connect a headset to your phone, you can set up your phone to use the headset automatically when answering and placing calls. To enable this feature, see the section [Use Your Headset for All Calls](#).



Troubleshooting: Why is my USB headset not displaying on my phone?

If your phone does not detect the USB headset when you attach it to your phone, the USB port on your phone may be disabled. Contact your system administrator and view the section [USB Port Issues](#) for more information.

Use Your Headset for All Calls

You can set up your phone so that all incoming and outgoing calls automatically use your headset. To use this feature, you must enable and activate Headset Memory Mode.

To enable and activate Headset Memory Mode:

- 1 Navigate to **Settings > Basic > Preferences > Headset > Headset Memory**.
For VVX 1500 phones, navigate to **Menu > Settings > Basic > Preferences > Headset > Headset Memory**.
- 2 From the **Headset Memory Mode** screen, select **Enabled**.
- 3 Press the headset key twice.

The headset key flashes to indicate that Headset Memory Mode is now activated. All calls placed or answered on your phone use your headset automatically.



Troubleshooting: Why do I hear an echo when I use my headset for calls?

If you or your contacts experience audio or echo issues during calls, such as feedback of your voice or of their own voice, you need to enable echo cancellation on your phone. View the section [Troubleshoot Audio and Echo Issues](#) for more information.

Reactivate Headset Memory Mode

Switching to the speakerphone or the handset deactivates Headset Memory Mode.

To reactivate Headset Memory Mode:

- » Press the headset key twice.

Using Electronic Hookswitch

When you use a headset that supports electronic hookswitch (EHS), you can place, answer, and end calls by using the controls on your headset. To use EHS, you need a headset that includes a serial control interface in addition to the standard analog headset jack (RJ-9) interface. The serial control interface requires an EHS adapter that you can purchase from your headset manufacturer.

Headsets that support EHS include a base unit that connects to your phone. The headset connects to the base unit wirelessly, which enables you to use your headset even if you're some distance away from your phone. Typically, you can work wirelessly up to 300 feet (91 meters) from your phone and still use the EHS controls. Check with your headset's user guide for the precise range restrictions.

See [Feature Profile 37477: Using Headsets with Polycom Phones](#) for a list of compatible headsets.

Setting the Headset Base Unit Options

Before you connect your headset to your phone and use EHS, you need to set the following options for your specific headset model:

- For Jabra headsets, change the headset mode to **DHSG** on the headset base unit. For details, refer to your headset documentation or contact Jabra support.
- For Plantronics headsets, change the coarse receive level to **3** and the transmit level to **B** on the headset base unit. For details, refer to the guide that comes with your headset.
- For Sennheiser headsets, set the first DIP switch labeled **1** (DHSG) to the down position on the back of the headset base unit. For additional details, see your headset's documentation or contact Sennheiser support.

Enable Electronic Hookswitch

After you set the base unit options for your headset and connect your headset to your phone, you can enable EHS.

To enable electronic hookswitch on your phone:

- 1 Connect your headset and EHS adapter to your phone.
See the Quick Start Guide for your phone on [Polycom Voice Support](#) for information on connecting a headset to your phone.
- 2 Navigate to **Settings > Basic > Preferences > Headset > Hookswitch Mode**.
For VVX 1500 phones, navigate to **Menu > Settings > Basic > Preferences > Headset > Hookswitch Mode**.
- 3 Select one of the below modes for your specific headset:
 - Choose **Jabra** if an EHS-compatible Jabra headset is attached with an EHS cable or adapter.
 - Choose **Plantronics** if an EHS-compatible Plantronics headset is attached with an EHS cable or adapter.
 - Choose **Sennheiser** if an EHS-compatible Sennheiser headset is attached with an EHS cable or adapter. If your phone does not have a menu selection for Sennheiser, select **Jabra** instead.
 - Choose **Regular Mode** (default) if another headset is attached.

Change the Headset Mode

Headsets that come with a docking station have two modes: soft phone and desk phone mode. In order for you to control your phone using your headset, your headset must be in soft phone mode. If you cannot operate the phone from your headset, it is possible your headset is in desk phone mode.

To change to soft phone mode:

- » Press and hold the headset hookswitch until you hear a sound or message on the headset.

Using Electronic Hookswitch

After you have followed the procedures for connecting your headset and enabled EHS, you can use the controls on your headset to answer, mute, and end calls. If supported on your headset, you can also place calls on hold. See your headset's user documentation for information on controlling calls from your headset.

When you are in an active call and you receive an incoming call, you cannot use the hookswitch control on your headset to place the active call on hold and answer the incoming call. Pressing the hookswitch control on the headset ends the active call and answers the incoming call. To place the existing call on hold and answer the incoming call, answer the call on your phone.

Disconnect Your Headset

If you want to disconnect or change your headset, you need to properly detach your headset from your phone.

To disconnect a headset:

- 1 Navigate to **Settings > Basic > Preferences > Headset > Hookswitch Mode**.
For VVX 1500 phones, navigate to **Menu > Settings > Basic > Preferences > Headset > Hookswitch Mode**.
- 2 Select **Regular Mode**.
- 3 Remove the EHS adapter from the serial port on the back of the phone.

Using Bluetooth Headsets with Your VVX 600 Phone

VVX 600 phones support Bluetooth headsets as well as analog and USB headsets. If your system administrator has enabled Bluetooth capability for your phone, you can use a Bluetooth headset to handle calls. When a Bluetooth headset is connected and in use, the headset key  glows blue. If you have multiple types of headsets connected to your phone, the Bluetooth headset is used automatically for all calls.



This section provides you with information on how to enable Bluetooth on your VVX 600, how to pair and connect your Bluetooth headset, how to use your Bluetooth headset with your phone, and how to disconnect and remove your headset.

Enable Bluetooth and Connect a Headset

In order to use a Bluetooth headset with your phone, you need to enable Bluetooth, pair your headset, and connect your Bluetooth device to your phone. You can pair up to four Bluetooth headsets with your phone; however, you can connect only one headset at a time.

The following instructions are intended as a guide, and do not apply to all Bluetooth devices. You can usually find instructions for your headset on the device manufacturer's web site.



To enable, pair, and connect your Bluetooth headset to your phone:

- 1 Navigate to **Settings > Basic > Bluetooth Settings > Bluetooth Radio**.
The Bluetooth Radio screen is displayed.
- 2 Tap **On**.
The Bluetooth icon  is displayed in the status bar. After the icon displays, you can pair and connect your Bluetooth headset.
- 3 Turn your Bluetooth headset on and place the headset in **Discovery** mode.
Refer to your headset documentation for information on how to place your headset in discovery mode.
- 4 Navigate to **Settings > Basic > Bluetooth Settings > Manage BT Headsets**.
- 5 Tap **Scan** to find your headset.
All nearby devices in discovery mode are added to the list, and a red Bluetooth icon  is displayed next to each unpaired headset.
- 6 Select your headset and tap **Add** to begin the pairing process.
After your headset is added, the **Manage BT Headsets** screen is displayed. Your headset is paired, and the Bluetooth icon is displayed next to the headset.
- 7 Select your headset and select **Connect**.
The Bluetooth Headset icon  is displayed next to your headset after the headset is paired and connected. The Bluetooth Headset icon is also displayed in the status bar. If you select the icon, the Bluetooth Settings screen is displayed.

You can now use your headset to handle calls.

Managing Calls with Your Bluetooth Headset

When your Bluetooth headset is turned on, paired, and connected with your phone, you can perform the following tasks:

- Use the headset to handle calls, including muting and adjusting the call volume.
- Initiate and end calls on your headset by pressing the Headset key , or using a control on the headset.
- Switch to handset or speakerphone mode during a headset call by picking up the handset or pressing the Speakerphone key .

When you turn the headset off, the headset is no longer connected but remains paired to your phone. When you turn the headset back on, the headset is reconnected.

Disconnect and Remove Your Bluetooth Headset

You can disconnect your headset from your phone, but still keep it paired. When you disconnect a headset, it remains paired so you can easily connect it to your phone again.

You can also remove your headset so that it is no longer paired or connected. When you remove your headset, it won't display in the Manage BT Headsets screen. To connect it back to your phone, you'll need to scan for the device, add it, and connect it again.

To disconnect and remove your headset:

- 1 Navigate to **Settings > Basic > Bluetooth Settings > Manage BT Headsets**.
- 2 From the **Manage BT Headsets** screen, select your headset, and select **Disconnect**.
Your headset remains paired to your phone but is no longer connected.
- 3 Select your headset, and select **Remove**.
Your headset is removed from the list and is no longer paired or connected with your phone.



Tip: How to quickly connect and disconnect your headset

You can quickly disconnect your headset by turning your headset off. When you turn it off, the message "Headset removed" is displayed. When you turn your headset back on, the headset is connected again.

Using the Polycom Desktop Connector

The Polycom Desktop Connector (PDC) enables you to use your computer mouse and keyboard to navigate and enter information on your phone. The PDC is compatible with any language your phone and computer supports. Contact your system administrator to find out if your phone supports the PDC.

This feature is not available on VVX 101 and 201 phones. Check with your system administrator to find out if this feature is available on your phone.

Setting Up and Enabling the Polycom Desktop Connector

Before you can enable and use the PDC, you need to download the PDC application from the [Polycom Voice Applications](#) website, install the application on your computer, and activate PDC on your phone.

To enable the PDC, you need to enter your computer access credentials to the phone. You can provide this information to your phone using one of two methods:

- [Use the Direct Method](#)
- [Using the Indirect Method](#)

The method you use depends on how your phone and computer are setup.

After you install the software, you need to make changes to your phone to establish a connection to your computer and provide an exception to your firewall or anti-virus software to unblock the PDC program.

Use the Direct Method

If your phone and computer are connected using an Ethernet cable, use the direct method to enable the PDC. Using this method, your phone automatically detects your computer's access credentials.

To connect using the direct method:

- 1 Click **Start > Programs > Polycom > Polycom Desktop Connector**.
The PDC icon is displayed as an active program on your taskbar, as shown next.

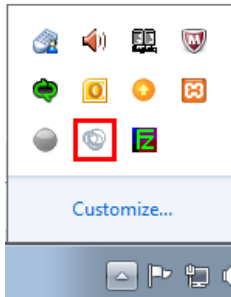

- 2 Navigate to the **PDC Configuration** screen on your phone:
 - For VVX 1500 phones, navigate to **Menu > Settings > Basic >PDC Configuration**.
 - For other VVX phones, navigate to **Settings > Basic >PDC Configuration**.The PDC Configuration screen is displayed on your phone screen.
- 3 On the **PDC Configuration** screen, set the **Status** field to **Enabled** and select **Save**.
Your settings are saved and the Basic screen is displayed.
- 4 On the **PDC Configuration** screen, select **Reconnect**.
- 5 A dialog box is displayed on your phone screen asking if you wish to share your remote keyboard and mouse. Select **Yes**.
- 6 A dialog box is displayed asking you to specify your phone's position. Specify whether your phone is to the left or right of your computer monitor.
- 7 A dialog box is displayed on your computer asking to allow remote control of your phone. Click **OK** to complete the setup process.
The PDC icon turns red, shown next, indicating that you have successfully enabled the PDC program.

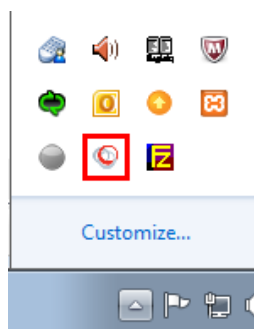

Using the Indirect Method

If your phone and computer are connected through a switch, use the indirect method to enable the PDC. This method requires you to find your computer's IP address and manually enter your computer access credentials.

Find Your Computer's IP Address

You can find your computer's IP address using the Command Prompt.

To find your computer's IP address:

- 1 Click **Start > All Programs > Accessories > Command Prompt**.

- 2 In the **Command Prompt**, type `ipconfig` and press **Enter**.
- 3 Note your server address on the **IPv4 Address** line, as shown next.

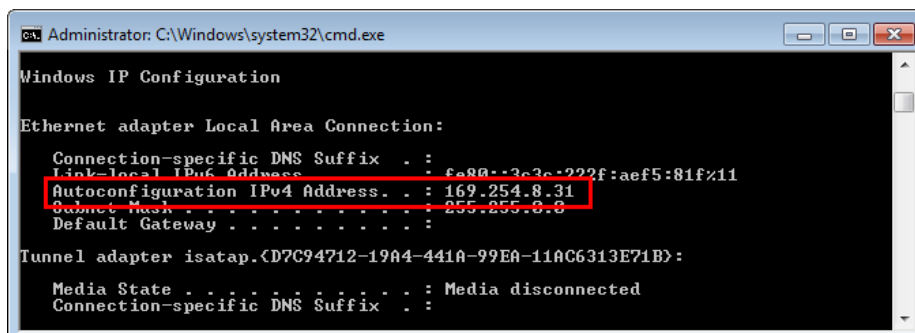

```
Administrator: C:\Windows\system32\cmd.exe
Windows IP Configuration

Ethernet adapter Local Area Connection:

    Connection-specific DNS Suffix  . : 
    Link-local IPv6 Address . . . . . : fe80::3c3c-222f:aef5:81f%11
    Autoconfiguration IPv4 Address. . : 169.254.8.31
    Subnet Mask . . . . . : 255.255.0.0
    Default Gateway . . . . . : 

Tunnel adapter isatap.{D7C94712-19A4-441A-99EA-11AC6313E71B}:

    Media State . . . . . : Media disconnected
    Connection-specific DNS Suffix  . :
```

Connect Using the Indirect Method

After you find your phone's IP address, you can start the PDC program and connect your phone to your computer using the indirect method.

To connect using the indirect method:

- 1 Click **Start > Programs > Polycom > Polycom Desktop Connector**.

The PDC icon is displayed as an active program on your taskbar as shown next.

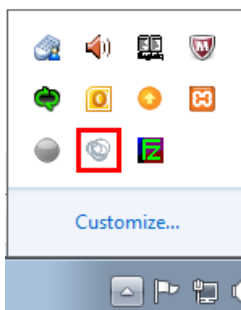

- 2 Navigate to the **PDC Configuration** screen on your phone:
 - For VVX 1500 phones, navigate to **Menu > Settings > Basic >PDC Configuration**.
 - For other VVX phones, navigate to **Settings > Basic >PDC Configuration**.
- 3 From the **PDC Configuration** screen, set the **Status** field to **Enabled**.
- 4 In the **Phone Orientation** field, specify whether your phone is to the left or right of your computer monitor.
- 5 In the **Desktop User** field, enter your Windows login name.
- 6 In the **Server Address** field, enter your computer's IP address or FQDN. The IP address enables your phone to locate and identify your computer on the network.
- 7 Select **Save**.

Your settings are saved and the Basic screen is displayed.
- 8 A message is displayed asking you to allow sharing with your computer. Select **Yes**.

- 9 A dialog box is displayed on your computer asking if you wish to allow remote control of your phone. Click **OK** to complete the setup process.

The PDC icon turns red, shown next, indicating that you have successfully enabled the PDC program.

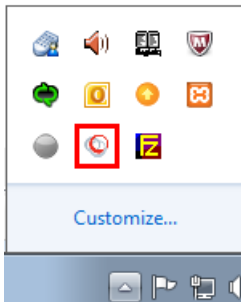

Disable the Polycom DesktopConnector

If you disable the PDC, you can no longer use your mouse and keyboard to control and enter information on your phone

To disable the PDC:

- » Do one of the following:
 - On your computer, right-click the PDC icon on your taskbar and click **Exit**.
 - On your phone, navigate to the PDC Configuration menu and set the **Status** to **Disabled**.

In the system tray, the PDC icon turns grey.

Using the Polycom DesktopConnector

After you've configured and enabled the PDC, you can use your computer mouse and keyboard to click menus and enter text in the editable fields—the fields with a flashing cursor—on your phone.

Access Your Phone Screens

You can use your mouse to navigate your phone and access your phone's screens.

To access your phone's screen using your mouse:

- » Move your mouse pointer off the edge of your computer monitor in the direction of your phone—left or right—that you indicated in the setup process.

The pointer leaves your computer monitor and appears on the phone's screen.



Troubleshooting: Why can't I access the phone's display screen?

If your computer taskbar is on the same side as your phone, the taskbar will block your cursor from accessing your phone. Move your computer taskbar elsewhere to allow your cursor to access the phone.

Using Keyboard Shortcuts to Perform Tasks on Your Phone

The PDC extends your keyboard and mouse functionality onto your phone and enables you to do the following:

- You can right-click a field on your computer and select the cut or copy information and cpaste the information onto your phone. You can also cut, copy and paste text from your computer onto your phone using keyboard shortcuts:
 - Cut (Ctrl+X)
 - Copy (Ctrl+C),
 - Paste (Ctrl+V).

You cannot cut, copy, and paste text from your phone to your computer.

- Copy and paste information between fields on your phone screen by right-clicking the field and choosing a clipboard command.
- Delete information on your phone by highlighting the information using your mouse and pressing the Delete or Backspace key on your keyboard.
- Use the Home and End keys on your keyboard to position your cursor at the beginning or the end of fields on your phone.
- Enter numeric information such as phone numbers using the number keys on your keyboard.
- Use the Arrow keys to move within and between text fields.
- Use your mouse scroll wheel to navigate through menus.
- Adjust the volume level on your phone by holding Alt + Up arrow key or Alt + Down arrow key.



Note: PDC limitations

When you use PDC, you cannot perform the following actions:





- Enter information in phone fields that don't have a flashing cursor.
- Place calls using the New Call soft key.

For more information, see the [Polycom Desktop Connector Issues](#) section.











Your keyboard function keys are also mapped to specific phone keys and soft keys, as outlined in the following tables. The key mappings vary by phone model.

To use the Function and Alt key mappings, your cursor must be on the phone's displayscreen.



Function and Alt Key Mappings for VVX 1500 Phones

Function Key	Phone Key	Alt Key	Phone Key
F1	Left-most soft key	Alt + F1	
F2	Second soft key from the left	Alt + F2	
F3	Third soft key from the left	Alt + F3	
F4	Fourth soft key from the left	Alt + F4	



Function and Alt Key Mappings for VVX 1500 Phones

Function Key	Phone Key	Alt Key	Phone Key
F5	Right-most soft key	Alt + F5	
F6	 	Alt + F6	
F7		Alt + F7	
F8		Alt + F8	New Call soft key
F9	Talk soft key (if PTT is enabled)	Alt + F9	End Call soft key
F10	NA	Alt + F10	Settings
F11		Alt + F11	
F12		Alt + F12	N/A

Function and Alt Key Mappings for VVX 300/310, 400/410, 500, and 600 Phones

Function Key	Phone Key	Alt Key	Phone Key
F1	First soft key from the left on your phone's current screen	Alt+F1	N/A
F2	Second soft key from the left on your phone's current screen	Alt+F2	Redial
F3	Third soft key from the left on your phone's current screen	Alt+F3	Transfer
F4	Fourth soft key from the left on your phone's current screen	Alt+F4	Conference
F6		Alt+F6	Do Not Disturb
F7	Directories menu	Alt+F7	
F8	Messages menu	Alt+F8	New Call soft key
F9	Talk soft key (if PTT is enabled)	Alt+F9	End Call soft key
F10	ACD Sign In (if enabled)	Alt+F10	Settings.

Function and Alt Key Mappings for VVX 300/310, 400/410, 500, and 600 Phones

F11	Applications	Alt+F11	
F12		Alt+F12	ACD Sign Out (if enabled)

Enter Text in a Different Language

You can also enter text in different languages onto your phone using your keyboard.



Note: You can't use the PinYin character entry method

The PDC does not allow you to type Chinese characters into fields on your phone using the PinYin character entry method on your computer keyboard. Instead, copy and paste these Chinese characters from a computer document into the applicable phone fields using your Windows clipboard functions.

To enter text in a different language:

- 1 On your computer, click **Start > Control Panel > Region and Language > Keyboard and Languages > Change keyboards.**
- 2 Choose a computer keyboard language, as shown next.

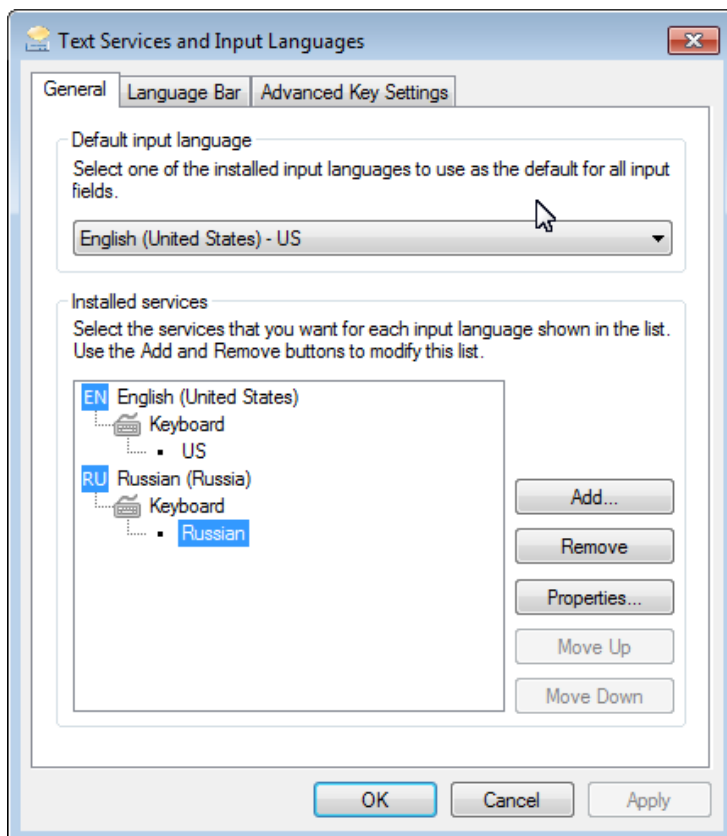

- 3 Move your cursor onto your phone's display screen.
The PDC program changes your keyboard language when you move your cursor onto your phone's screen.
- 4 On the phone, enter text in your chosen language.
In the following graphic, Russian characters are entered on the VVX 500.

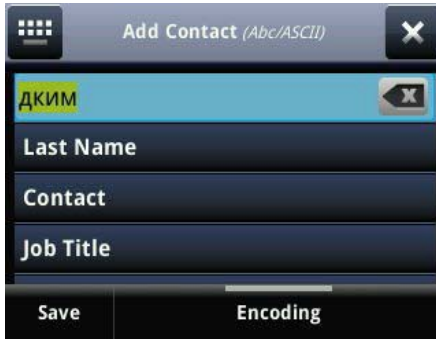

Tip: Change your keyboard language back to default

To change your keyboard language back to the original, press the keyboard shortcut **Left Alt + Left Shift** to toggle your keyboard language.

See the section [Polycom Desktop Connector Issues](#) for solutions to possible troubleshooting issues.

Connecting Polycom VVX Expansion Modules to Your Phone

The Polycom VVX Expansion Modules are consoles you can connect to Polycom VVX Business Media phones to add additional lines. VVX Expansion Modules enable you to handle large call volumes on a daily basis and expand the functions of your phone.

VVX 101, 201, and 1500 phones do not support VVX Expansion Modules. Check with your system administrator to find out if your phone is set up to support VVX Expansion Modules.



Note: VVX Expansion Modules not supported in UC Software 5.0.x

The VVX Expansion Modules are not supported on VVX phones running UC Software 5.0.x. The expansion modules are supported only on VVX phones running UC Software 4.1.6, 4.1.7, and 5.1.x and later.

The following features are available on the VVX Color Expansion Modules and VVX Expansion Modules with a paper display:

- *VVX Color Expansion Modules* VVX Color Expansion Modules feature an easy-to-navigate 480x272 LCD display. Each color expansion module provides you with 28 line keys and three display pages, supporting a total of 84 lines that you can set up as registrations, favorites, busy lamp field contacts. You can connect up to three color expansion modules to your phone to support an additional 252 line keys per phone.
- *VVX Expansion Modules* VVX Expansion Modules provide you with 40 line keys that you can set up as registrations, favorites, or busy lamp field contacts. You can connect up to three expansion modules to your phone to support an additional 120 line keys per phone.

View VVX Expansion Module Hardware Features

The following figure illustrates the features, components, and keys available on the VVX Color Expansion Modules. The table lists each numbered feature shown in this figure.

VVX Color Expansion Module features

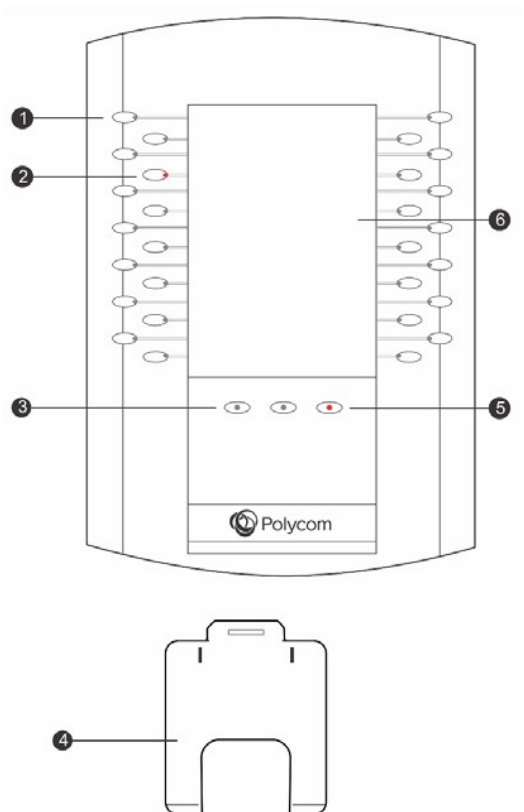

VVX Color Expansion Module Hardware Feature Descriptions

Reference Number	Feature	Feature Description
1	Line Key	Selects available line key contacts, functions, and assignments.
2	LED Indicators	Indicates a line or busy lamp field contact's status. The following lists the LED Indicator behaviors shown on the expansion modules: <ul style="list-style-type: none"> • <i>Solid Green</i> Indicates an active call in progress. • <i>Fast-Flashing Green</i> Indicates an incoming call. • <i>Flashing Green</i> Indicates the remote party placed the call on hold. • <i>Solid Red</i> Indicates the phone of a monitored busy lamp field contact is placing a call or is in a call. • <i>Flashing Red</i> Indicates a held call. • <i>Flashing Green and Red</i> Indicates the phone of a monitored busy lamp field contact is on an active call or is receiving an incoming call.
3	Page Keys	Navigates between pages on the expansion module.
4	Base Stand	Hooks into the back of the expansion module to stand up the display.
5	LED Page Indicators	Indicates a page's status.
6	Color Display	Displays line numbers, busy lamp field contacts, contacts and favorites.

- *Fast-Flashing Green* displays the contact's status as not currently in a call.
- *Slow-Flashing Green* displays the contact's status as not currently in a call.
- *Solid Red* displays the contact's status as currently in a call.

The next figure illustrates the features, components, and keys available on the VVX Expansion Modules with a paper display. The table lists each numbered feature shown in this figure.

VVX Expansion Module with paper display features

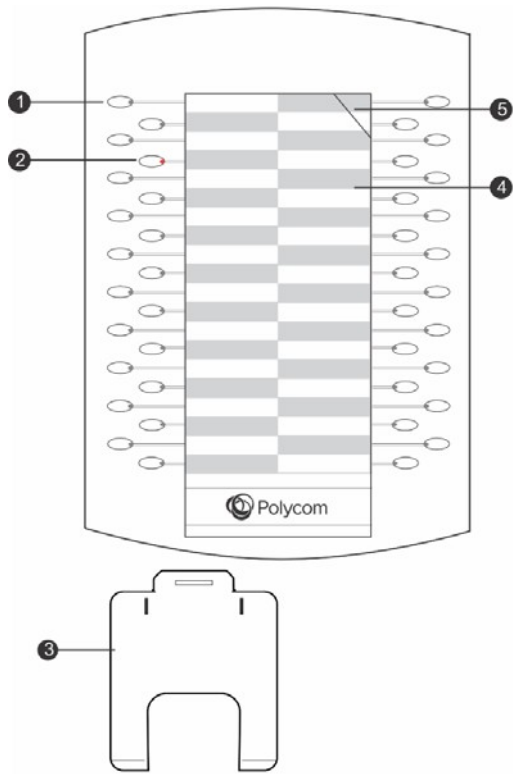

VVX Expansion Module Hardware Feature Descriptions

Reference Number	Feature	Feature Description
1	Line key	Selects available line key contacts, functions, and assignments.
2	LED Indicators	Indicates a line or busy lamp field contact's status. The following lists the LED Indicator behaviors shown on the expansion modules: <ul style="list-style-type: none"> • <i>Solid Green</i> Indicates an active call in progress. • <i>Fast-flashing Green</i> Indicates an incoming call. • <i>Flashing Green</i> Indicates the remote party placed the call on hold. • <i>Solid Red</i> Indicates the phone of a monitored busy lamp field contact is placing a call or is in a call. • <i>Flashing Red</i> Indicates a held call.
3	Base Stand	Hooks into the back of the expansion module to stand up the display.

VVX Expansion Module Hardware Feature Descriptions

Reference Number	Feature	Feature Description
4	Plastic Cover Overlying Directory Card	Protects the directory numbers, busy la
5	Plastic Cover Cut Out	Helps insert or

Connect VVX Expansion Modules

VVX Expansion Modules are powered and signaled by VVX phones and require minimal setup. After you connect an expansion module to a VVX phone, the module is automatically configured to work with the phone. Note that you cannot connect paper display and color display expansion modules together on the same phone.



Web Info: Setting up Expansion Modules

For more information on setting up VVX Expansion Modules, see the [Quick Start Guide for Polycom VVX Expansion Modules](#).

To connect the VVX Expansion Module to your phone:

- » Connect an auxiliary cable from the **AUX** port on the phone to the **AUX 1** port on the expansion module.

The LED lights on the module's line keys flash red and green as the module starts up. The VVX Color Expansion Modules takes approximately 20 seconds to power up, and the VVX Expansion Modules with a paper display take approximately three seconds to power up.

Connect Additional Expansion Modules

After the first module is on, you can connect up to two additional modules to your VVX phone.

To connect multiple VVX Expansion Modules:

- 1 Connect an auxiliary cable from the **AUX 2** port on the first module connected to the phone to the **AUX 1** port on the second module.
- 2 Connect an auxiliary cable from the **AUX 2** port on the second module to the **AUX 1** port on the third module.

The LED lights on the line keys light up for each connected module as the expansion modules start up.

Using VVX Expansion Modules

This section includes the following topics on how to use the VVX Expansion Modules with your VVX phone:

- [Assigning Busy Lamp Field Contacts and Favorites](#)
- [Generate the VVX Expansion Module Directory Card](#)

- [Navigate VVX Color Expansion Module Paging](#)
- [Changing the Backlight Intensity](#)

Assigning Busy Lamp Field Contacts and Favorites

The default view on your phone screen, which is the Lines screen, displays line registrations, busy lamp field contacts, and favorites. Each function occupies a display space on the Lines screen. VVX phones support a maximum number of display spaces, which are listed in the following table. When you reach the maximum number of display spaces on your phone, the next function you add is assigned to the first available line on your expansion module.

Maximum Number of VVX Phone Display Spaces

VVX Phone Model	Maximum Display Spaces Supported
VVX 300/310	6
VVX 400/410	12
VVX 500	12
VVX 600	16

Assign Favorites

You can assign favorites to line keys on VVX Expansion Modules and automatically call contacts using the line keys on the expansion modules. When you assign favorites on your phone, favorites are assigned to the next available line key on the expansion module regardless of the index number. You can reorder your favorites once they are created by changing the value of their index number. See the section [Managing Favorites](#) for more information.

To assign a favorite on the VVX Expansion Module:

- 1 Press and hold an available line key on your expansion module.
- 2 From the **Add Contact** screen, enter the contact's information, including a unique favorite index, and select **Save**.

VVX 500 and 600 phones automatically assign a favorite index. The favorite is assigned to the next available line on your expansion module and not necessarily the line corresponding to the line key you pressed to assign the favorite.

Identify Line Key Assignments

You can identify which registrations, busy lamp field contacts, and favorites are assigned to each line key on your expansion module in the Status menu on your VVX phone.

To identify line key assignments:

- 1 Navigate to **Settings > Status > Line Key Information**.
- 2 Press a line key on the expansion module.
The assignment and line number for the line key you pressed is displayed on your phone's screen.
- 3 Press the line key twice to return to the previous menu, or select **Back**.

Generate the VVX Expansion Module Directory Card

Using the Polycom Web Configuration Utility, you can generate and download a PDF file with your VVX Expansion Module line key information. You can print and insert the PDF file as a directory card on your expansion module.



Settings: Accessing the Web Configuration Utility Disabled by Default

Access to the Web Configuration Utility may be disabled by default as a security precaution. Contact your system administrator for help enabling the Web Configuration Utility.

To generate and download the directory card using the Web Configuration Utility:

- 1 In your Internet browser, enter your phone's IP address into your browser's address bar.
To find your phone's IP address, navigate to **Settings > Status > Platform > Phone**.
- 2 Log in as a **User**, enter the default password **123**, and click **Submit**.
- 3 Click **Utilities > EM Directory**.
- 4 Select the VVX Expansion Module you want to generate a PDF for. For example, *EM1* is chosen in the following figure.

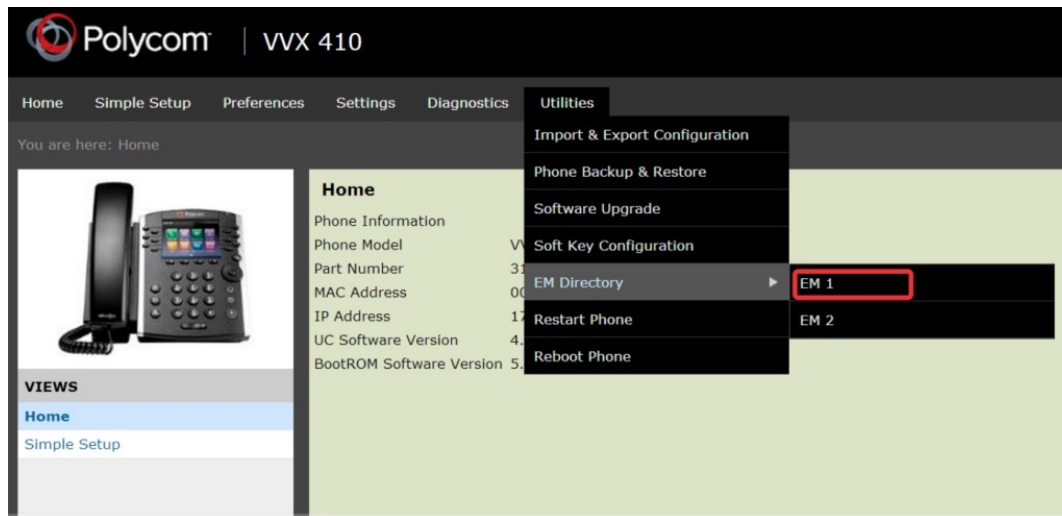

- 5 In the confirmation dialog box, select **Yes** to download the directory card.
- 6 Select **Save > Open**.
The directory card is displayed.

Insert the Directory Card on the VVX Expansion Module

After you download the directory card, you can print and insert the directory card on your VVX Expansion Module.

To insert the directory card on the VVX Expansion Module with a paper display:

- 1 Place the tip of a paper clip under the plastic cover cut out of the VVX Expansion Module plastic cover to remove it.
- 2 Place the directory card on your VVX Expansion Module.
- 3 Align the tabs on either side of the plastic cover with the corresponding indents on the expansion module and bend the plastic cover into place to reinsert the cover over the directory card for protection.

Navigate VVX Color Expansion Module Paging

The VVX Color Expansion Modules display three pages of line information on the LCD screen for each module connected to a VVX phone. Each page of the expansion module contains 28 registrations, busy lamp field contacts, or favorites assigned to line keys.

To navigate between VVX Color Expansion Module pages:

- » Press a Page key beneath the screen on the VVX Color Expansion Module.

Using Smart Paging

The Smart Paging feature arranges line key assignments and distributes pages on the VVX Color Expansion Modules based on the number of expansion modules connected to a VVX phone. Smart Paging is automatically enabled for VVX Color Expansion Modules connected to VVX phones with UC Software 5.1.0 or later.

Smart Paging does not affect how pages are ordered on VVX Expansion Modules with paper displays.



Note: Smart Paging does not affect Flexible Line Key assignments

If you assigned functions to line keys using the Flexible Line Key feature, the line key assignments display on the designated line key on the expansion module and are not affected by Smart Paging.

When Smart Paging is enabled, the pages on the VVX Color Expansion Module are distributed across all connected expansion modules. This feature is described and shown in the following scenarios:

- If you only have one expansion module connected to your VVX phone, the pages are ordered sequentially on the module, as shown in the next figure. Press the first, second, or third **Page** key to view the corresponding pages.



- If you have two expansion modules connected to your VVX phone, the pages are ordered non-sequentially. As shown in the next figure, the pages display on the two expansion modules in the following order:
 - Pages 1, 3, and 4 display on the first expansion module.
 - Pages 2, 5, and 6 display on the second expansion module.

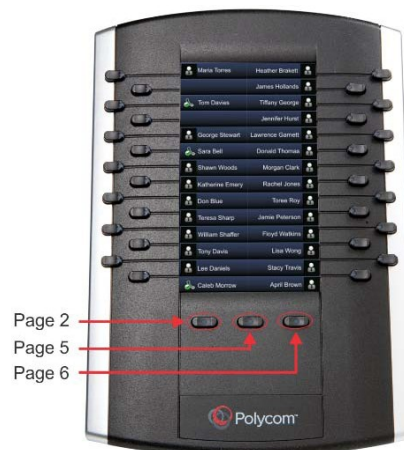
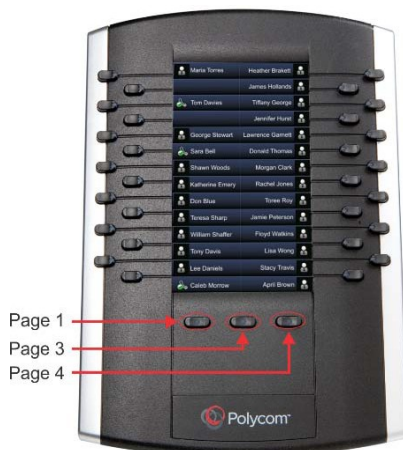

- If you have three expansion modules connected to your VVX phone, the pages are ordered non-sequentially. As shown in the next figure, the pages display on the three expansion modules in the following order:

- Pages 1, 4, and 5 display on the first expansion module.
- Pages 2, 6, and 7 display on the second expansion module.
- Pages 3, 8, and 9 display on the third expansion module.

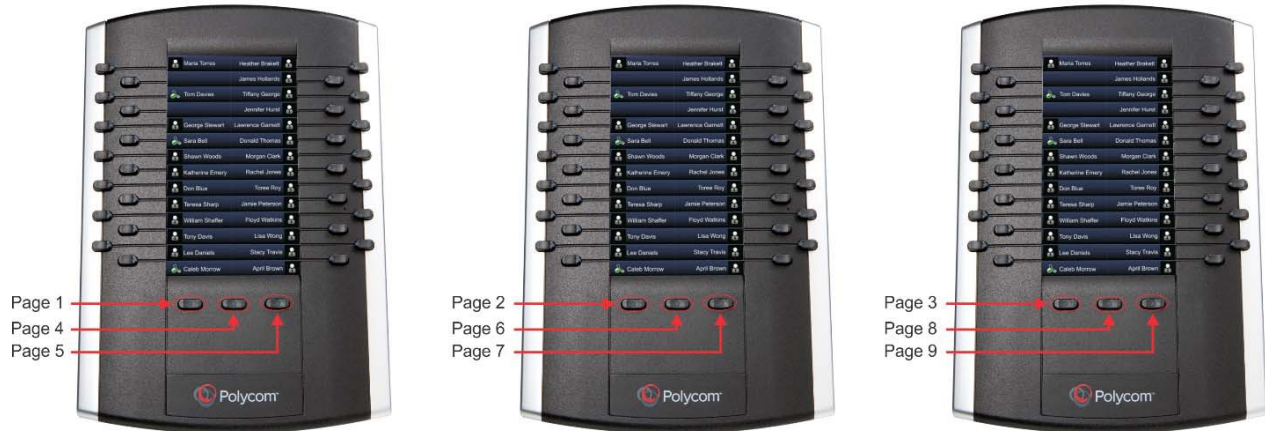

Using Alternate Paging

When Smart Paging is disabled, the ordering of the pages on the expansion modules is not affected by the number of expansion modules connected to your VVX phone. With Alternate Paging, the expansion modules' pages are ordered sequentially from 1 to 9. The next figure shows Alternate Paging on three expansion modules.

Alternate Paging on VVX Color Expansion Modules



Changing the Backlight Intensity

When you change the backlight intensity settings on your VVX phone, the backlight on your VVX Color Expansion Module connected to your phone automatically changes to match the new settings. See the section [Setting the Backlight Intensity and Timeout](#) for information on changing this setting.

Maintenance Tasks

When your phone is unable to operate properly, you need to investigate or troubleshoot issues among other tasks your administrator may ask you to perform. This section shows you how to perform the following maintenance tasks:

- [Investigate Phone Warnings](#)
- [Restart the Phone](#)
- [Update the Phone Configuration](#)
- [Test Phone Hardware](#)
- [Clean the Touchscreen](#)
- [View Software Details](#)
- [Update the Phone Software](#)

Investigate Phone Warnings

When your phone is unable to perform certain tasks, a Warning icon  is displayed in the status bar. The warning icon lets you know that your phone has one or more important issues. You can view details about the issues from the Warnings screen. If you have a VVX 600, the icon has a counter indicating the number of warning messages you have, and you can tap the icon to view the messages.

To view a detailed list of phone issues:

- » Navigate to **Settings > Status > Diagnostics > Warnings**.
On VVX 1500 phones, navigate to **Menu > Status > Diagnostics > Warnings**.
The **Warnings** screen is displayed listing any phone issues.

Remove Warnings

After you view the phone warnings, you can temporarily remove the Warning icon from the status bar. However, the warning still displays in the Warnings list until the issue is fixed. The Warning icon is displayed each time your phone has a warning that you haven't viewed.

To temporarily remove warnings:

- » In the **Warnings** screen, select **Clear Icon** to remove the Warning icon from the status bar.

Restart the Phone

Your system administrator may ask you to restart your phone if your phone malfunctions or to assist in troubleshooting.



Caution: Restarting your phone

Before you restart your phone, contact your system administrator. If your phone is malfunctioning, you may be able to restore normal operation without restarting the phone. In addition, your administrator may want to troubleshoot your phone before you restart it.

If you need to update your phone's configuration, don't restart your phone. Instead, see the section [Update the Phone Configuration](#).

To restart the phone:

- 1 Navigate to **Settings > Basic > Restart Phone**.
On VVX 1500 phones, navigate to **Menu > Settings > Basic > Restart Phone**.
A confirmation message is displayed.
- 2 Select **Yes**.
The restart process begins, and the process ends when the Home screen is displayed.

Update the Phone Configuration

Your system administrator may ask you to update your phone configuration, which you can do without restarting your phone.

To update your phone's configuration:

- 1 Navigate to **Settings > Basic > Update Configuration**.
On VVX 1500 phones, navigate to **Menu > Settings > Basic > Update Configuration**.
A confirmation message is displayed.
- 2 Select **Yes**.
The configuration is updated. Your phone may restart, depending on the phone settings that have changed.

Test Phone Hardware

Your system administrator may ask you to access a diagnostics menu on your phone to test its hardware. You can test your phone's microphones, speaker, handset, third-party headset (if connected), keypad mappings, touchscreen, and LEDs. See your system administrator for instructions on how to perform these tests.

To test your phone hardware:

- 1 Navigate to **Settings > Status > Diagnostics > Test Hardware**.
On VVX 1500 phones, navigate to **Menu > Status > Diagnostics > TestHardware**.

- 2 From the **Test Hardware** screen, select one of the following:
 - **Audio Diagnostics**
 - **Keypad Diagnostics**
 - **Display Diagnostics**
 - **Touch Screen Diagnostics**
 - **Brightness Diagnostics**
 - **LED Diagnostics**

Clean the Touchscreen

The touchscreen on VVX 500, 600, and 1500 phones requires minor maintenance, but you may periodically need to clean the touchscreen. Use a clean, dry, microfiber cloth—the kind you would use to clean glass surfaces—to wipe the touchscreen.

Before you clean the screen, disable it so you don't activate phone functions while you wipe the touchscreen.

To clean the touchscreen:

- 1 Navigate to **Settings > Basic > Screen Clean**.
On VVX 1500 phones, navigate to **Menu > Settings > Basic > Screen Clean**.
- 2 Wipe the screen with a clean, dry, microfiber cloth.
- 3 Press any key on the phone dial pad to enable the touchscreen again.



Note: What happens if I clean the touchscreen, but it's still dirty?

Dampen a soft, lint-free cloth with an isopropyl alcohol and water solution of 50:50, and then wipe the screen with the cloth. Always use the dampened cloth to apply the solution; never apply the solution directly to the touchscreen, which could seep inside the screen or stain the phone. In addition, do not use chemicals to clean the touchscreen.

View Software Details

You can view the details for the software version on your phone, the latest software update available for your phone, and the status of the latest update.

To view details for the software on your phone:

- » Navigate to **Settings > Status > Software Update**.
For VVX 1500 phones, navigate to **Menu > Settings > Status > Software Update**.

Update the Phone Software

You can update the software on your phone when a new software version is available. When new software is available, a notification is displayed on your phone, and you have the option to update your software, postpone the software update, or exit the notification.

When the software update notification is displayed on your phone, you can choose to update your phone's software at that time.

To update your phone's software:

- » When prompted to update your software, select **Update**.

The phone reboots and the software is updated on the phone.

Exit the Software Update Notification

When the software update notification is displayed, you also have the option to exit the notification without choosing to update or postpone the software.

To exit the software update notification:

- » When prompted to update your software, select **Exit**.

When you exit the notification, the SWUpdate soft key is displayed on the Lines screen.

Update Software Later

If you exit the software update, you can press the SWUpdate soft key to update your phone's software at any time after you exit the software update notification.

To update your phone's software later:

- » Press the **SWUpdate** soft key.

Postpone Software Updates

Instead of updating your software immediately, you can choose to postpone the update for a later time. You can choose to postpone the software for 15 minutes or up to six hours. You can postpone the software update up to three times. After the third time, the notification is displayed without the Postpone option.

To postpone the software update:

- 1 When prompted to update your software, select **Postpone**.
- 2 Select one of the time options.

The notification is removed from the phone screen and is displayed again during the remaining five minutes of the postpone time selected.

If you do not update the phone's software after the postpone time, a notification with a countdown is displayed, and the phone automatically reboots and updates the software when the countdown ends.



Note: What if the postponed time ends during an active call?

If you postpone a software update and the time period you chose ends while you're on an active call, a software update notification with a countdown is displayed after the call ends. After the countdown ends, the phone reboots and updates the software.

Troubleshoot Issues

This section lists potential issues, problems, and common difficulties and possible solutions to guide you towards resolving those issues. This section includes the following troubleshooting topics:

- [General Phone Issues](#)
- [Application Issues](#)
- [Login Issues](#)
- [Polycom Desktop Connector Issues](#)
- [Headset Issues](#)
- [Recording Issues](#)

General Phone Issues

This section includes potential issues and solutions for general phone issues.

Speakerphone Issues

If your speakerphone doesn't work, your system administrator may have disabled it. If this is the case, a message is displayed informing you that Handsfree is disabled after you press the speakerphone key. In this case, use the handset or a headset to handle calls.

USB Port Issues

If you attach a USB device to your VVX 500, 600 or 1500 phone, and the phone does not detect the attached USB device, your system administrator may have disabled the USB port on your phone. In this case, you cannot attach a USB flash drive to your phone to use the following features:

- Call recording
- Picture frame
- USB headset
- VVX Camera for video calls on VVX 500 and 600 phones
- USB charging device on the VVX 600

Contact your system administrator for help on enabling the USB port on your phone.

Application Issues

This section includes solutions to troubleshooting issues for applications on your phone.

Troubleshoot Calendar Issues

When you do not see the Calendar icon on the Home screen, or you are not receiving meeting reminders, it is possible that your phone is not connected to the Microsoft Exchange Server.

To reconnect to the server and use the Calendar feature again:

- 1 Navigate to **Settings > Features > Calendar**.
- 2 From the **Calendar** screen, select **Connect**.

Login Issues

If your phone has incorrect login credentials, or if you need to re-submit Login Credentials, one of the following messages or icons display on your phone:

- The message “Login Credentials have failed. Please update them if the information is correct” is displayed on the screen.
- A red lock icon  is displayed under the time in the statusbar.
- The message “Invalid login credentials” scrolls under the time in the statusbar.
- The Calendar icon that displays on the Home screen is not available.

See the section [Log Into and Lock Your Phone](#) for more information on entering your login credentials or contact your system administrator.

Polycom Desktop Connector Issues

If you encounter any issues using the Polycom Desktop Connector, see the following table for possible solutions to common problems.

Common PDC Problems and Solutions

Issue	Corrective Action
The computer and phone cannot establish a connection.	
I can't enter information in a phone field using my computer keyboard.	
I can't place a call.	If you're using PDC, you can't place a call using the New Call soft key. To place a call, enter the phone number and select the Dial soft key or tap the Dial icon  .
I want to change the phone that is connected to the Polycom Desktop Connector.	

Verify phone
Record

Check to see
You can use
field if the f

Follow the ins
the Polycom

Polycom Desktop Connector, which is already connected to your computer and is in active state on your phone.

Setup and enable the phone you want to connect to Polycom Desktop Connector. Once your computer receives an initial communication from the newly configured phone, it asks you to confirm the connection by

displaying the
<MACaddress
change to co

Headset Issues

This section includes solutions to troubleshooting issues when using a headset with your VVX phone.

Troubleshoot Audio and Echo Issues

In some cases when you are using your headset, your contacts may experience audio or echo issues, such as feedback of your voice or of their own voice, during the call. If your contacts hear an echo during a call when using your headset, you need to enable echo cancellation on your phone.

To enable echo cancellation on your phone:

- 1 Navigate to **Settings > Basic > Preferences > Headset > Echo Cancellation**.
For VVX 1500 phones, navigate to **Menu > Settings > Basic > Preferences > Headset > Echo Cancellation**.
- 2 Select **Enabled**.

Bluetooth Headset Issues

If you encounter any issues using a Bluetooth headset, see the following table for possible solutions to common problems.

Common Bluetooth Headset Issues and Solutions

Issue	Corrective Action
The Bluetooth settings do not display on my phone	Do one of the following: <ul style="list-style-type: none"> • Check with your system administrator to see if the Bluetooth feature is enabled on your phone. • Make sure the Bluetooth Radio setting is on. See Enable Bluetooth and Connect a Headset.
My headset doesn't pair automatically.	If your headset is an older model, you may need to enter a password before the headset can pair with your phone. Refer to your headset documentation for more information.

Recording Issues

If you encounter any issues recording calls, see the following table for possible solutions to common problems.

Common Recording Issues and Solutions

Issue	Corrective Action
The message "USB device is full. Recording canceled" is displayed when I pressed Start.	

Check that there is a free drive.

Common Recording Issues and Solutions

The recording stopped during a call.

If the USB flash drive becomes full during recording, recording stops and the message “USB device is full. Recording stopped” is displayed.

Delete previous recordings to make space on the USB drive. See the section [Browse Recorded Calls](#) for information on deleting recordings.

The message “USB device removed unsafely. Recording canceled” displayed when I removed my USB flash drive during a call.

The message “Unsupported USB device attached” displayed.

Do not re
you want
and then

Refer to [Tech
Devices](#) for a
Polycom pho

Get Help

For additional information about the Polycom VVX Business Media Phones, the VVX Camera, and the VVX Expansion Modules, view the following support pages:

- [BluIP Private Partner Resource Page](#)

You can view the following types of documents on each product page:

- **User Documents:**
 - *Quick User Guide* A quick reference on how to use the phone's most basic features.
 - *User Guide* A full reference on the phone's features and functions.

You can also contact BluIP Support at CALL 855.GO.BLUIP (462.5847).

Copyright, Safety, and Regulatory Notices

Service Agreements

Please contact BluiP for information about service agreements applicable to your product.

Governing Law

This Limited Warranty and Limitation of Liability shall be governed by the laws of the State of California, U.S.A., and by the laws of the United States, excluding their conflicts of laws principles. The United Nations Convention on Contracts for the International Sale of Goods is hereby excluded in its entirety from application to this Limited Warranty and Limitation of Liability.

All rights reserved under International and Pan-American Copyright Conventions. No part of the contents of this manual may be copied, reproduced, or transmitted in any form or by any means, or translated into another language or format, in whole or part, without written consent from Polycom, Inc. Do not remove (or allow anybody else to remove) any product identification, copyright, or other notices.

Limitations of Liability

LIMITATION OF LIABILITY. TO THE FULL EXTENT ALLOWED BY LAW, POLYCOM EXCLUDES FOR ITSELF AND ITS SUPPLIERS ANY LIABILITY, WHETHER BASED IN CONTRACT OR TORT (INCLUDING NEGLIGENCE), FOR INCIDENTAL, CONSEQUENTIAL, INDIRECT, SPECIAL, OR PUNITIVE DAMAGES OF ANY KIND, OR FOR LOSS OF REVENUE OR PROFITS, LOSS OF BUSINESS, LOSS OF INFORMATION OR DATA, OR OTHER FINANCIAL LOSS ARISING OUT OF OR IN CONNECTION WITH THE SALE, INSTALLATION, MAINTENANCE, USE, PERFORMANCE, FAILURE, OR INTERRUPTION OF ITS PRODUCTS, EVEN IF POLYCOM OR BLUIP HAS BEEN ADVISED OF THE POSSIBILITY OF SUCH DAMAGES, AND LIMITS ITS LIABILITY TO REPAIR, REPLACEMENT, OR REFUND OF THE PURCHASE PRICE PAID, AT POLYCOM'S OPTION. THIS DISCLAIMER OF LIABILITY FOR DAMAGES WILL NOT BE AFFECTED IF ANY REMEDY PROVIDED HEREIN SHALL FAIL OF ITS ESSENTIAL PURPOSE.

Polycom Limited Warranty and Limitation Liability

LIMITED WARRANTY. Polycom warrants to the end user ("Customer") that this product is expected to be free from defects in workmanship and materials, under normal use and service, for one year from the date of purchase from Polycom or BluiP.

Polycom's sole obligation under this express warranty is at Polycom's option and expense, to repair the defective product or part, deliver to Customer an equivalent product or part to replace the defective item, or

if neither of the two foregoing options are reasonably available, Polycom may, on its sole discretion, refund to Customer the purchase price paid for the defective product. All products that are replaced will become the property of Polycom. Replacement products or parts may be new or reconditioned.

Polycom is expected to warrant any replaced or repaired product or part for ninety (90) days from shipment, or the remainder of the initial warranty period, whichever is longer. Products returned to Polycom must be sent prepaid and packaged appropriately for safe shipment, and it is recommended that they be insured or sent by a method that provides for tracking of the package. Responsibility for loss or damage does not transfer to Polycom until the returned item is received by Polycom. The repaired or replaced item will be shipped to Customer, at Polycom's expense, not later than thirty (30) days after Polycom receives the defective product, and Polycom will retain risk of loss or damage until the item is delivered to Customer.

The product software comes with 90-day software warranty, providing for software updates (minor releases/bug fixes). To continue to receive support, purchasing a maintenance contract is the most economical solution.

Exclusions

Polycom will not be liable under this limited warranty if its testing and examination disclose that the alleged defect or malfunction in the product does not exist or results from:

- Failure to follow Polycom's installation, operation, or maintenance instructions.
- Unauthorized product modification or alteration.
- Unauthorized use of common carrier communication services accessed through the product.
- Abuse, misuse, negligent acts or omissions of Customer and persons under Customer's control; or
- Acts of third parties, acts of God, accident, fire, lightening, power surges or outages, or other hazards.

Warranty Exclusive

IF A POLYCOM PRODUCT DOES NOT OPERATE AS WARRANTED ABOVE, CUSTOMER'S SOLE REMEDY FOR BREACH OF THAT WARRANTY SHALL BE REPAIR, REPLACEMENT, OR REFUND OF THE PURCHASE PRICE PAID, AT POLYCOM'S OPTION. TO THE FULL EXTENT ALLOWED BY LAW, THE FOREGOING WARRANTIES AND REMEDIES ARE EXCLUSIVE AND ARE IN LIEU OF ALL OTHER WARRANTIES, TERMS, OR CONDITIONS, EXPRESS OR IMPLIED, EITHER IN FACT OR BY OPERATION OF LAW, STATUTORY OR OTHERWISE, INCLUDING WARRANTIES, TERMS, OR CONDITIONS OF MERCHANTABILITY, FITNESS FOR A PARTICULAR PURPOSE, SATISFACTORY QUALITY, CORRESPONDENCE WITH DESCRIPTION, AND NON-INFRINGEMENT, ALL OF WHICH ARE EXPRESSLY DISCLAIMED. POLYCOM NEITHER ASSUMES NOR AUTHORIZES ANY OTHER PERSON TO ASSUME FOR IT ANY OTHER LIABILITY IN CONNECTION WITH THE SALE, INSTALLATION, MAINTENANCE OR USE OF ITS PRODUCTS.

Safety, Compliance, and Disposal Information

Part 15 FCC Rules

This device is compliant with Part 15 of the FCC Rules. Operation is subject to the following two conditions:

- This device may not cause harmful interference, and

- This device must accept any interferences received, including interference that may cause undesired operation.

Class B Digital Device or Peripheral

Note: This equipment is tested and complies with the limits for a Class B digital device, pursuant to Part 15 of the FCC Rules. These limits are designed to provide reasonable protection against harmful interference in a residential installation. This equipment generates, uses, and can radiate radio frequency energy and, if not installed and used in accordance with the instructions, may cause harmful interference to radio communications. However, there is no guarantee that interference will not occur in a particular installation. If this equipment does cause harmful interference to radio or television reception, which can be determined by turning the equipment off and on, the user is encouraged to try to correct the interference by one or more of the following measures:

- Reorient or relocate the receiving antenna.
- Increase the separation between the equipment and receiver.
- Connect the equipment into an outlet on a circuit different from that to which the receiver is connected.
- Consult the dealer or an experienced radio/TV technician for help.

Class A Digital Device or Peripheral - VVX Expansion Modules

Note: This equipment has been tested and found to comply with the limits for a Class A digital device, pursuant to Part 15 of the FCC Rules. These limits are designed to provide reasonable protection against harmful interference when the equipment is operated in a commercial environment. This equipment generates, uses, and can radiate radio frequency energy and, if not installed and used in accordance with the instructions, may cause harmful interference to radio communications. Operation of this equipment in a residential area is likely to cause harmful interference in which case the user will be required to correct the interference at his own expense.

Modifications

In accordance with Part 15 of the FCC Rules, the user is cautioned that any changes or modifications not expressly approved by Polycom, Inc. could void the user's authority to operate the equipment. This equipment may not be used on a coin service or party line.

Installation Instructions

Installation must be performed in accordance with all relevant national wiring rules.

L'Installation doit être exécutée conformément à tous les règlements nationaux applicable au filage électrique.

When using Power over Ethernet (PoE), the equipment is to be connected only to PoE networks without connections to the outside plant.

Plug Acts as Disconnect Device

The socket outlet to which this apparatus is connected must be installed near the equipment and must always be readily accessible.

La prise électrique à laquelle l'appareil est branché doit être installée près de l'équipement et doit toujours être facilement accessible.

Industry Canada (IC)

This Class [B] digital apparatus complies with Canadian ICES-003.

Cet appareil numérique de la classe [B] est conforme à la norme NMB-003 du Canada.

Industry Canada (IC) - VVX Expansion Modules

This Class [A] digital apparatus complies with Canadian ICES-003.

Cet appareil numérique de la classe [A] est conforme à la norme NMB-003 du Canada.

CE and VCCI Mark

These VVX 101, 201, 300, 310, 400, 410, 500, 600, and 1500 business media phones are marked with the CE mark. This mark indicates compliance with EC Directive 1999/5/EC.

The VVX Camera and VVX Expansion Modules are marked with the CE mark. This mark indicates compliance with LVD & EMC Directives 2006/95/EC & 2004/108/EC.

A full copy of the Declaration of Conformity can be obtained from Polycom Ltd., 270 Bath Road, Slough, Berkshire, SL1 4DX, UK.

CE Mark R & TTE Directive (EU only)

Česky [Czech]: Polycom (UK) Ltd tímto prohlašuje, že tento VVX 101/201/300/310/400/410/500/600/1500 je ve shodě se základními požadavky a dalšími příslušnými ustanoveními směrnice 1999/5/ES.

Dansk [Danish]: Undertegnede Polycom (UK) Ltd erklærer herved, at følgende udstyr VVX 101/201/300/310/400/410/500/600/1500 overholder de væsentlige krav og øvrige relevante krav i direktiv 1999/5/EF.

Deutsch [German]: Hiermit erklärt Polycom (UK) Ltd, dass sich das Gerät VVX 101/201/300/310/400/410/500/600/1500 in Übereinstimmung mit den grundlegenden Anforderungen und den übrigen einschlägigen Bestimmungen der Richtlinie 1999/5/EG befindet.

Eesti [Estonian]: Käesolevaga kinnitab Polycom (UK) Ltd seadme VVX 101/201/300/310/400/410/500/600/1500 vastavust direktiivi 1999/5/EÜ põhinõuetele ja nimetatud direktiivist tulenevatele teistele asjakohastele sätetele.

English: Hereby, Polycom (UK) Ltd. declares that this VVX 101/201/300/310/400/410/500/600/1500 is in compliance with the essential requirements and other relevant provisions of Directive 1999/5/EC.

Español [Spanish]: Por medio de la presente Polycom (UK) Ltd declara que el VVX 101/201/300/310/400/410/500/600 cumple con los requisitos esenciales y cualesquiera otras disposiciones aplicables o exigibles de la Directiva 1999/5/CE.

Ελληνική [Greek]: ΜΕ ΤΗΝ ΠΑΡΟΥΣΑ Polycom (UK) Ltd ΔΗΛΩΝΕΙ ΟΤΙ VVX 101/201/300/310/400/410/500/600/1500 ΣΥΜΜΟΡΦΩΝΕΤΑΙ ΠΡΟΣ ΤΙΣ ΟΥΣΙΩΔΕΙΣ ΑΠΑΙΤΗΣΕΙΣ ΚΑΙ ΤΙΣ ΛΟΙΠΕΣ ΣΧΕΤΙΚΕΣ ΔΙΑΤΑΞΕΙΣ ΤΗΣ ΟΔΗΓΙΑΣ 1999/5/ΕΚ.

Français [French]: Par la présente Polycom (UK) Ltd déclare que l'appareil VVX 101/201/300/310/400/410/500/600/1500 est conforme aux exigences essentielles et aux autres dispositions pertinentes de la directive 1999/5/CE.

Italiano [Italian]: Con la presente Polycom (UK) Ltd dichiara che questo VVX 101/201/300/310/400/410/500/600/1500 è conforme ai requisiti essenziali ed alle altre disposizioni pertinenti stabilite dalla direttiva 1999/5/CE.

Íslenska [Icelandic]: Hér með lýsir Polycom (UK) Ltd yfir því að VVX 101/201/300/310/400/410/500/600/1500 er í samræmi við grunnkröfur og aðrar kröfur, sem gerðar eru í tilskipun 1999/5/EC

Latviski [Latvian]: Ar šo Polycom (UK) Ltd deklarē, VVX 101/201/300/310/400/410/500/600/1500 atbilst Direktīvas 1999/5/EK būtiskajām prasībām un citiem ar to saistītajiem noteikumiem.

Lietuvių [Lithuanian]: Šiuo Polycom (UK) Ltd deklaruoja, kad šis VVX 101/201/300/310/400/410/500/600/1500 atitinka esminius reikalavimus ir kitas 1999/5/EB Direktyvos nuostatas.

Nederlands [Dutch]: Hierbij verklaart Polycom (UK) Ltd dat het toestel VVX 101/201/300/310/400/410/500/600/1500 in overeenstemming is met de essentiële eisen en de andere relevante bepalingen van richtlijn 1999/5/EG.

Malti [Maltese]: Hawnhekk, Polycom (UK) Ltd, jiddikjara li dan VVX 101/201/300/310/400/410/500/600/1500 jikkonforma mal-ħtiġijiet essenzjali u ma provvedimenti oħrajn relevanti li hemm fid-Dirrettiva 1999/5/EC.

Magyar [Hungarian]: Alulírott, Polycom (UK) Ltd nyilatkozom, hogy a VVX 101/201/300/310/400/410/500/600/1500 megfelel a vonatkozó alapvető követelményeknek és az 1999/5/EC irányelv egyéb előírásainak.

Norsk [Norwegian]: Polycom (UK) Ltd erklærer herved at utstyret VVX 101/201/300/310/400/410/500/600/1500 er i samsvar med de grunnleggende krav og øvrige relevante krav i direktiv 1999/5/EF.

Polski [Polish]: Niniejszym Polycom (UK) Ltd oświadcza, że VVX 101/201/300/310/400/410/500/600/1500 jest zgodne z zasadniczymi wymaganiami oraz innymi stosownymi postanowieniami Dyrektywy 1999/5/WE

Português [Portuguese]: Polycom (UK) Ltd declara que este VVX 101/201/300/310/400/410/500/600/1500 está conforme com os requisitos essenciais e outras disposições da Directiva 1999/5/CE.

Slovensko [Slovenian]: Polycom (UK) Ltd izjavlja, da je ta VVX 101/201/300/310/400/410/500/600/1500 v skladu z bistvenimi zahtevami in ostalimi relevantnimi določili direktive 1999/5/ES.

Slovensky [Slovak]: Polycom (UK) Ltd týmto vyhlasuje, že VVX 101/201/300/310/400/410/500/600/1500 spĺňa základné požiadavky a všetky príslušné ustanovenia Smernice 1999/5/ES.

Suomi [Finnish]: Polycom (UK) Ltd vakuuttaa täten että VVX 101/201/300/310/400/410/500/600/1500 tyyppinen laite on direktiivin 1999/5/EY oleellisten vaatimusten ja sitä koskevien direktiivin muiden ehtojen mukainen.

Svenska [Swedish]: Härmed intygar Polycom (UK) Ltd att denna VVX 101/201/300/310/400/410/500/600/1500 står i överensstämmelse med de väsentliga egenskapskrav och övriga relevanta bestämmelser som framgår av direktiv 1999/5/EG.

Japan VCCI

この装置は、クラスB情報技術装置です。この装置は、家庭環境で使用することを目的としていますが、この装置がラジオやテレビジョン受信機に近接して使用されると、受信障害を引き起こすことがあります。
取扱説明書に従って正しい取り扱いをして下さい。 VCCI-B

この装置は、クラスA情報技術装置です。この装置を家庭環境で使用すると電波妨害を引き起こすことがあります。この場合には使用者が適切な対策を講ずるよう要求されることがあります。 VCCI-A

WARNING Electrical Safety

VVX 101 and 201 Phones

To avoid electric shock, do not connect safety extra low voltage (SELV) circuits to teleconference station network (TNV) circuits. LAN ports contain SELV circuit, and WAN ports contain TNV circuits. Some LAN and WAN ports both use RJ-45 connectors. Use caution when connecting cables.

This product is rated 12Vdc, 0.5A. When used with the optional external power supply (MU08-6120050-xx, or similar rated PSU), the power supply shall be a Listed power supply with a LPS output, rated 12V, min. 0.5A.

VVX 300, 310, 400, and 410 Phones

To avoid electric shock, do not connect safety extra low voltage (SELV) circuits to teleconference station network (TNV) circuits. LAN ports contain SELV circuit, and WAN ports contain TNV circuits. Some LAN and WAN ports both use RJ-45 connectors. Use caution when connecting cables.

This product is rated 48Vdc, 0.25A. When used with the optional external power supply (PSA15A-480PV, or similar rated PSU), the power supply shall be a Listed power supply with a LPS output, rated 48V, min. 0.25A.

VVX 500 and 600 Phones

To avoid electric shock, do not connect safety extra low voltage (SELV) circuits to teleconference station network (TNV) circuits. LAN ports contain SELV circuit, and WAN ports contain TNV circuits. Some LAN and WAN ports both use RJ-45 connectors. Use caution when connecting cables.

These products are rated 48Vdc, 0.375A. When used with the optional external power supply (PSC18U-480, or similar rated PSU), the power supply shall be a Listed power supply with a LPS output, rated 48V, min. 0.38A. The VVX Camera is USB powered (5VDC 0.5A) only.

VVX 1500 Phones

To avoid electric shock, do not connect safety extra low voltage (SELV) circuits to teleconference station network (TNV) circuits. LAN ports contain SELV circuit, and WAN ports contain TNV circuits. Some LAN and WAN ports both use RJ-45 connectors. Use caution when connecting cables.

This product is rated 48Vdc, 0.375A. When used with the optional external power supply, the power supply shall be a Listed power supply with a LPS output, rated 48V, min. 0.375A.

Russian Compliance

VVX 300: Ministry of Information Technologies & Communication of the Russian Federation – Declaration of Conformity. Д-СПД-6090 valid till 01/March/2016.

VVX 310: Ministry of Information Technologies & Communication of the Russian Federation – Declaration of Conformity. Д-СПД-6091 valid till 01/March/2016.

VVX 400: Ministry of Information Technologies & Communication of the Russian Federation – Declaration of Conformity. Д-СПД-6089 valid till 01/March/2016.

VVX 410: Ministry of Information Technologies & Communication of the Russian Federation – Declaration of Conformity. Д-СПД-6092 valid till 01/March/2016.

VVX 500: Ministry of Information Technologies & Communication of the Russian Federation – Declaration of Conformity. Д-СПД-6854 valid until 14/10/2017.

VVX 600: Ministry of Information Technologies & Communication of the Russian Federation – Declaration of Conformity. Д-СПД-6013 valid until 27/11/2015.

VVX 1500: Ministry of Information Technologies & Communication of the Russian Federation - Declaration of Conformity. Д-СПД-6855. Valid until 14/10/2017.

Ukrainian Compliance

Инструкции по установке

Установка должна быть выполнена в полном соответствии со всеми действующими государственными нормами прокладки кабелей. При питании оборудования по сети Ethernet (PoE), оборудование должно подключаться только к сетям, поддерживающим PoE. Оборудование нельзя подключать к цепям линейных сооружений.

Вилки в качестве разъединителя

Розетка, к которой подключается данный аппарат, должна устанавливаться вблизи соответствующего оборудования и всегда быть легко доступной для подключения.

ПРЕДУПРЕЖДЕНИЕ. Электробезопасность

Во избежание поражения электрическим током не подключайте цепи с малым по условиям безопасности напряжением (БСНН) к сети станции телеконференции. Цепи (НТС). Порты LAN содержат цепи БСНН, порты WAN содержат цепи НТС. Для некоторых портов LAN и WAN используются разъемы RJ-45. Соблюдайте осторожность при подключении кабелей. Напряжение питания данного изделия составляет 48 В, 0,375 А постоянного тока. При использовании дополнительного внешнего источника питания, он должен быть внесен в списки UL, иметь ограниченную выходную мощность (LPS), номинальное напряжение 48 В и минимальный ток 0,375 А.

New Zealand Telepermit

VVX 300: PTC 220/12/085

VVX 310: PTC 220/12/086

VVX 400: PTC 220/12/087

VVX 410: PTC 220/12/088

VVX 500: PTC 220/11/098

VVX 600: PTC 220/12/058

VVX 1500: PTC 220/08/082

Special Conditions for this User Guide

- **PTC General Warning**

The grant of a Telepermit for any item of terminal equipment indicates only that Telecom has accepted that the item complies with minimum conditions for connection to its network. It indicates no endorsement of the product by Telecom, nor does it provide any sort of warranty. Above all, it provides no assurance that any item will work correctly in all respects with another item of Telepermitted equipment of a different make or model, nor does it imply that any product is compatible with all of Telecom's network services.

- **Echo Cancellation**

Echo cancellers are not normally required in the Telecom PSTN because geographic delays are acceptable where CPE return loss is maintained within Telepermit limits. However, those private networks making use of Voice over IP technology are required to provide echo cancellation for all voice calls. The combined effect of audio / VoIP conversion delay and IP routing delay can cause the echo cancellation time of 64 mS or more to be required.

- **Software Versions in the Polycom VVX VoIP Desktop Telephones When Used on the Telecom Network**

- The VVX 300 and 310 must be equipped with the software installed during the PTC testing (version 6.4.1.0008) for compliance to be guaranteed.
- The Polycom VVX 400 and 410 must be equipped with the software installed during the PTC testing (version 6.4.1.0008) for compliance to be guaranteed.
- The Polycom VVX 500 must be equipped with the software installed during the PTC testing (version 6.4.1.0008) for compliance to be guaranteed.
- The Polycom VVX 600 must be equipped with the software installed during the PTC testing (version 4.1.0.xxxx) for compliance to be guaranteed.

Connection of this Polycom VVX 1500 VoIP Video Telephone to the Telecom Network

All samples of this Polycom VVX 1500 VoIP Video Telephone connected to the Telecom network must be modified as described in KTL Test Report number 8A1710ANZ1 failure to do so will lead to the cancellation of this Telepermit.

UAE

Dealer No: 0017133/09

TRA Registered No:

- VVX 300: ER0104551/13
- VVX 310: ER0104074/13
- VVX 400: ER0104069/13
- VVX 410: ER0104109/13
- VVX 500: ER0082247/12
- VVX 600: ER0102187/13
- VVX 1500: 0017802/09

Australia

Warning: This equipment will not operate when main power fails.

Warning for all Polycom phones that use handsets

With respect to section 5.4.3.11 of the Australian Communications Authority as Telecommunications Technical Standard AS/ACIF S004 2006:

You should be aware that, under certain operating conditions, the handset earpiece may retain small metallic objects. If this occurs, these objects should be removed before using the handset.

Operating Ambient Temperatures

- Operating temperature: +32 to 104°F (0 to 40°C)
- Relative humidity: 5% to 95%, noncondensing
- Storage temperature: -40 to +160°F (-40 to +70°C)

Hearing Aid Compatibility (HAC)

This product is hearing aid compatible.

Waste Electrical and Electronic Equipment (WEEE)



All Polycom products that fall within the scope of the EU WEEE Directive carry the crossed wheeled bin symbol which advises customers not to recycle electronic products in the domestic waste stream but to recycle them safely as e-waste.

Restriction of Hazardous Substances Directive (RoHS)

All Polycom products comply with the requirements of the EU RoHS Directive. Statements of compliance can be obtained by contacting TypeApproval@polycom.com.

Polycom Take Back

In addition to any mandated take back requirement, Polycom offers free recycling of its branded products to business users. Detailed information is available at the [Polycom Takeback & Recycle Program](#) site.

Applies to VVX 600 Phones Only

Radiation Exposure Statement: The antenna used for this transmitter must be installed to provide a separation distance of at least 20 centimeters from all persons and must not be co-located or operating in conjunction with any other antenna or transmitter.

FCC Radiation Exposure Statement: This portable device with its antenna complies with FCC's RF radiation exposure limits set forth for an uncontrolled environment. To maintain compliance this transmitter must not be co-located or operating in conjunction with any other antenna or transmitter. FCC registration number: M72-VVX600.

This device complies with RSS-210 of Industry Canada. Operation is subject to the following two conditions: 1) This device may not cause interference, and 2) this device must accept any interference, including interference that may cause undesired operation of the device. Privacy of communications may not be ensured when using this telephone. Certification Number IC:1849C-VVX600.